

JANUARY 2023

Electrical

Products & Solutions™

The Purchasing Guide for Electrical Contractors

www.epsmag.net



iTOOLco -

Changing what's expected.

CORDLESS CANNON 6K

iTOOLco.

WWW.iTOOLco.com | 865.670.3713



Speed, versatility, and performance are all yours with iTOOLco's Cordless Cannon 6K™. This portable 6,000 lb. puller is intuitively designed to handle all of your day-to-day wire pulls.

The built-in capstan switch automatically turns the puller on and off. Simply tug on the rope to start the pull and slack off the rope to shut it down. Delivers dynamic performance in remote locations or areas where power is not yet available.



DRIVEN TO DELIVER

THE CONSOLE X



- Clean up those cabs and get your fleet organized!

Your Total Mobile Office Solution

The Truck Console -X combines your Laptop Work Station, Radios, Speakers, Cables, Storage and Cup Holders. No Drill Installation Brackets Included.

The **Truck Console -X** is the latest innovative mobile office solution to join the Mobile Desk brand family of products. This complete control, communication and convenience Utility Truck Console is becoming the new standard for fleets of all sizes. The design of the **Truck Console -X** has originated from our years of experience working directly with the lineman, supervisors, communications, and fleets of some of the most notable utility companies in America. Loaded with standard and optional features that maximize ergonomics, productivity, and fleet/telecom standards into one Mobile Office Solution.

Screen Out™ SCREEN-DISABLER™

Blanks your screen while you drive!

Our Patented Screen Out App **Stops texting** while driving for all employees on all tablets, laptops and smart phones that run Windows, iOS or Android Operating Systems. *It's that easy!*

877-663-3375 Ext 303. www.screenout.net

Find us on:



MOBILE DESK

MOBILE OFFICE SOLUTIONS

1-877-663-3375
www.mobiledesk.com

©2018 Mobiledesk

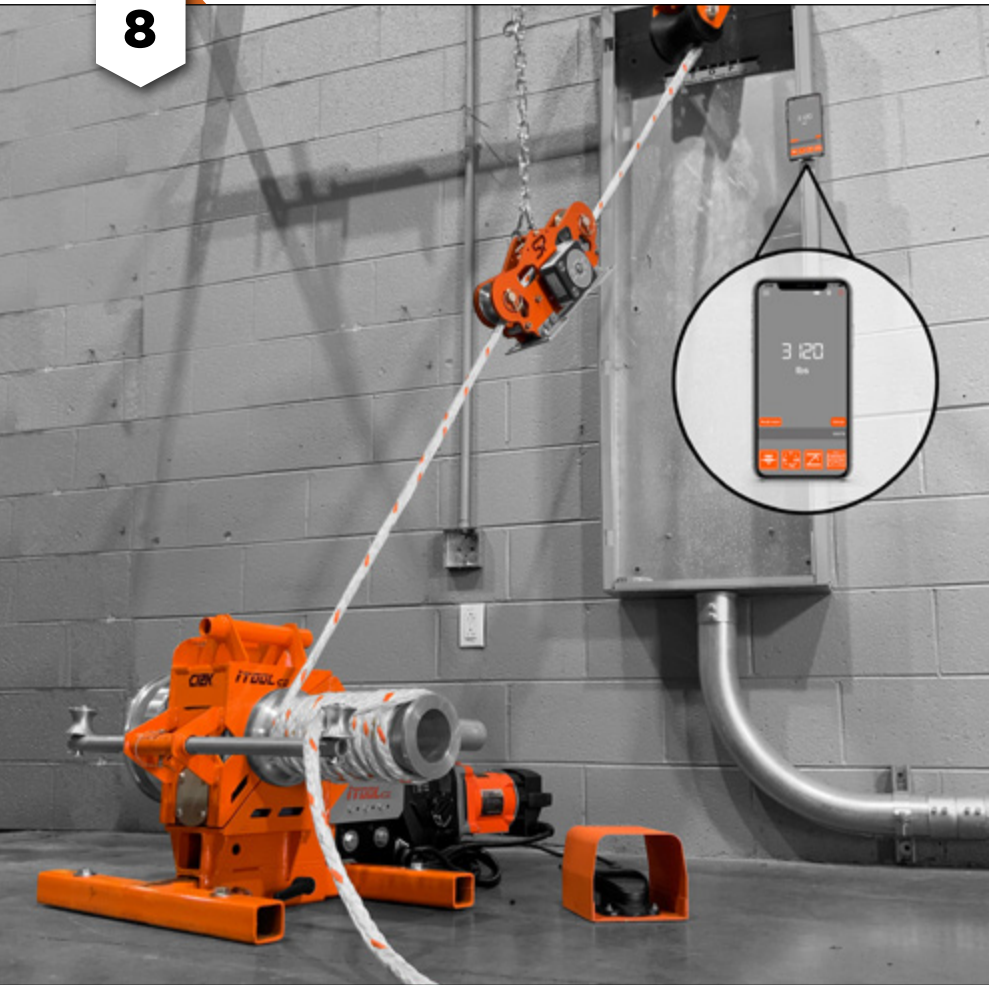

COMPANY PROFILE

6 Protect Yourself
Miller Safety Consultants —
A Leader in Arc Flash Protection

COVER STORY

8 iTOOLco—
Changing what's expected.
BY CALVIN JORDAN

DEPARTMENTS

- 16** INDUSTRY NEWS
- 22** NEW PRODUCTS
- 32** AD INDEX

ON THE COVER

Photo courtesy of iTOOLco

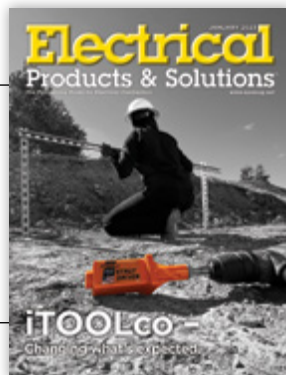

Electrical Products & Solutions™
The Purchasing Guide for Electrical Contractors www.epsmag.net

PUBLISHER
Danny J. Salchert

OFFICE MANAGER
Anita Salchert

CREATIVE DIRECTOR
Derek Gaylard

CIRCULATION DIRECTOR
Pam Fulmer

CONTRIBUTING WRITER
Calvin Jordan



PRESIDENT
Danny J. Salchert

EXECUTIVE AND ADVERTISING OFFICES
2009 Eagle Ridge Drive
Birmingham, AL 35242
phone: 205.981.4541
www.epsmag.net
danny@epsmag.net

Electrical Products & Solutions™ is published twelve times a year on a monthly basis by ABD Communications, Inc., 3591 Cahaba Beach Road, Birmingham, Alabama, 35242, USA. *Electrical Products & Solutions™* is distributed free to qualified subscribers. Non-qualified subscription rates are \$57.00 per year in the U.S. and Canada and \$84.00 per year for foreign subscribers (surface mail). U.S. Postage paid at Birmingham, Alabama and additional mailing offices. *Electrical Products & Solutions™* is distributed to qualified readers in the electrical contracting industry. Publisher is not liable for all content (including editorial and illustrations provided by advertisers) of advertisements published and does not accept responsibility for any claims made against the publisher. It is the advertiser's or agency's responsibility to obtain appropriate releases on any item or individuals pictured in an advertisement. Reproduction of this magazine in whole or in part is prohibited without prior written permission from the publisher.

POSTMASTER: Send address changes to ABD Communications, Inc., P.O. Box 382885 Birmingham, Alabama 35238-2885

FOLLOW US ON



SPPRODUCTS, INC.
Productivity and value thru ideas
FOR SAFER BETTER FASTER JOBS



We're Proud to be the Electricians' Friend for Over 50 Years!

Qwik Duct
Safer Better Faster

HDPE CUSTOM TEMPLATES
In Any Configuration Required

Save on Installation!

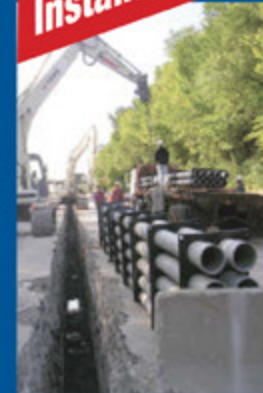

IP1

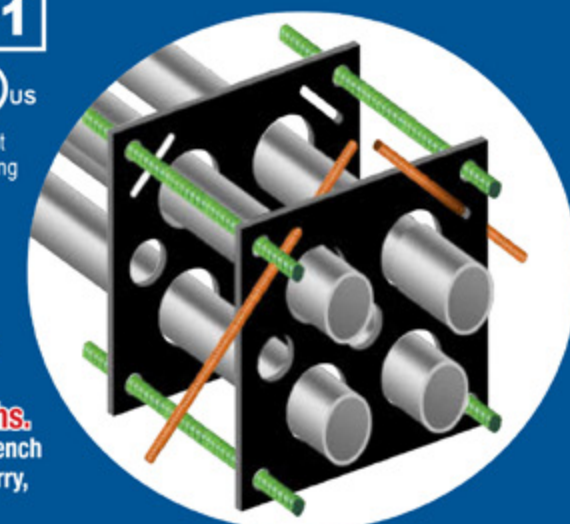

Assemble Conduit Above Trench -
No Workers Below -
Prevents Injuries and Deaths.
Also Allows Digging a Narrower Trench for Less: Excavation, Concrete, Slurry, Backfill & Shoring.

IP3b

Patent Pending



PVC Offset

Sizes 1/2" thru 6"
Meets Flexible Mandrel Test Requirements

Bore Spacers

Sizes 1/2" thru 6"
Roll assembled conduit into caissons and under obstructions

IP2



IP13A-F

Conduit Transition Couplings

PVC Schedule 40 & 80
Transitions in Less Than
5 Minutes



IP15

End Bell Adapter
Schedule 40/80 PVC
PATENT PENDING

Save Cost on the Rigid Nipple, Tape & Labor
Use for Entire Job - Not Just for Repair

IP14a

1 Piece Reaming Bit
1/2" thru 6"
Schedule 40/80
PATENT PENDING

Plus More Being Invented for **SAFER BETTER FASTER** Jobs . . . Call With Your Ideas!



SPProducts.com **800-233-8595** info@SPProducts.com

REPAIR CONDUIT IN A SNAP!

No Tape • No Plastic Straps • No Metallic Straps

NO KIDDING!

Designed especially for power, communications and fiber optics.



STEP 1
Remove damaged conduit

STEP 2
Cut split duct conduit to fit

STEP 3
Snap in place

STEP 4
Attach adapters

STEP 5
Finish job in record time

“The World Leader In Split Conduit Products”



Conduit Repair Systems, Inc.
The World Leader In Split Conduit Products



800.670.1804 • 435.673.8724 fax • crs@conduitrepair.com • www.conduitrepair.com



The right tool for every application

TOOLS you can TRUST

Partner with the TOOL fox for ergonomic tooling solutions that will boost your productivity with consistent, high-quality results. Phoenix Contact's wide variety of hand and semiautomatic tools allow you to cut, strip, crimp, and assemble with ease. Backed by our Limited Lifetime Warranty, a dedicated sales team, tech service, and UL listing when used with Phoenix Contact ferrules, our tools provide you with confidence in all your industrial and electrical cabinet-building needs.

For more information and to request a brochure or an on-site demonstration, please visit: www.phoenixcontact.com/us-TOOLfox.



© PHOENIX CONTACT 2023



Protect Yourself

Miller Safety Consultants — A Leader in Arc Flash Protection

Vince Miller started Miller Safety Consultants, a veteran owned business in 1999. The goal of the business was to provide cost effective safety consulting, employee training such as: confined space entry, fall protection, electrical safety and provide sales of electrical shock and flash protective equipment and fall protection equipment to businesses in the Washington DC area.

Reliance Industries provided fall protection products and much of the sales and training was on behalf of the supplier. In 2000, the owner decided to retire from his business, and Vince decided to discontinue the fall protection line of his business and concentrate more in the electrical training and products.

Vince had been a distributor for Certified Insulated Products (CIP), a manufacturer of electrical insulated tools and electrical arc flash clothing manufactured by Otex in Rochester, New York. As a distributor, Vince provided sales through his internet website and much through relationships with electrical contractors. His training was a classroom environment and was provided directly to customers but he also taught as a sub-contractor for other safety consulting companies and the

Chesapeake Safety Council in Baltimore, Maryland. In 2005, Vince partnered with Vivid Learning Systems in Cascades, Washington to provide on-line training in safe work practices.

Training in electrical safe work practices is still provided locally in the Washington DC area and as a partner with an electrical engineering firm and online. The training is based on the Occupational Health and Safety Administration (OSHA) standards and the National Fire Protection Association (NFPA) 70E standard.

Miller Safety Consultants is now a distributor for Cementex USA, Burlington, New Jersey, for insulated tools and equipment and clothing from OTEX Protective, Rochester, New York.

The majority of his sales of products

are from the web-based store. Cementex is nationally known for their quality equipment. Otex Protective is becoming more known for their quality clothing. For years, they have manufactured their products under other provider labels. Vince chose to not create his clothing line, but to sell the manufacturer product.

Vince has worked with many electrical company employees to fine-tune the clothing to be more comfortable for the user. Working closely with the manufacturer, they have made slight changes in how the cloth pattern was modified to meet final production. An example is the lightweight 40 Calorie vented hood offered by Otex.

The material is of the latest technology. The vented assembly is constructed for balance on the back of the hardhat and the airflow is 27 CFM to prevent fogging of the face shield and provide cooling to the worker. It took over a year to develop the product with the user prior to having the hood "flash tested". This product is now standard issue with many electrical contractors.

Being a small business and having quality providers has resulted in satisfied customers for Miller Safety Consultants. Being a direct supplier for OTEX Protective, another small business means customized customer needs can be met. □

For more information, visit
Miller Safety Consultants at:
www.electricalsafety.com, email
Vince at: sales@millersafetyltd.com.

AUTHORIZED
Cementex
The Safety Tool Specialists
DISTRIBUTOR

Give Vince a call at
(703) 367-0404



Deluxe Maintenance Tool Kit



Class O Glove Kit

Protect yourself from "Arc Flash"

ARC FLASH LIFT-FRONT HOOD WITH V¹² HIGH-VOLUME VENTILATOR
Compact. Powerful. Reliable

Our V¹² High-Volume Ventilator boasts an unexpectedly quiet, high output (35+ CFM) turbine fan to cool and circulate the ambient air within the hood. Fully protected beneath it's durable ABS shell and added fabric layering, the V¹² High-Volume Ventilator isn't just compliant, it's superior.



40 CAL/CM2 ULTRALIGHT CLOTHING BY OTEX

Our new dual-layer Ultralight clothing takes advantage of DuPont's® dedication to scientific advancement and Westex's® industry leading dependability. Weighing in 37% lighter than traditional HRC4 PPE, our Ultralight Clothing is the most innovative contender in the lightweight arena.

HYBRID LAYERING

Combined Fabric Weight: 14 oz

Outer Layer: DuPont® Protera
Color: Navy

Inner Layer: Westex Ultrasoft
Color: Safety Orange



CALL US TODAY
(703) 367-0404

OR VISIT OUR ONLINE ELECTRICAL SAFETY EQUIPMENT STORE
www.electricalsafety.com

iTOOLco - *Changing what's expected.*

BY CALVIN JORDAN, DIRECTOR OF MARKETING

iTOOLco IS A UNIQUE RESEARCH AND DEVELOPMENT COMPANY that has led the electrical tool industry with their groundbreaking designs since 2001. iTOOLco's inventors & Co-Founders David & Michael Jordan have developed and patented countless Innovative products, pushing the envelope of what can be done to improve the lives of electricians and distribution partners alike.

Awarded many prestigious accolades, including numerous NECA Showstopper Awards. iTOOLco is known for its groundbreaking work in the electrical field. Based in Clinton, TN – they are dedicated to creating the highest quality American made products, backed by an industry leading 6-year warranty.

With real world experience as

electrical contractors, brothers David and Michael Jordan have a deep understanding of the kind of quality, time-saving tools electricians depend on for doing the job right. Over the years iTOOLco has revolutionized the wire pulling market with the introduction of the first ever 12,000 lb. puller - the Cannon 12K, with built in reverse.

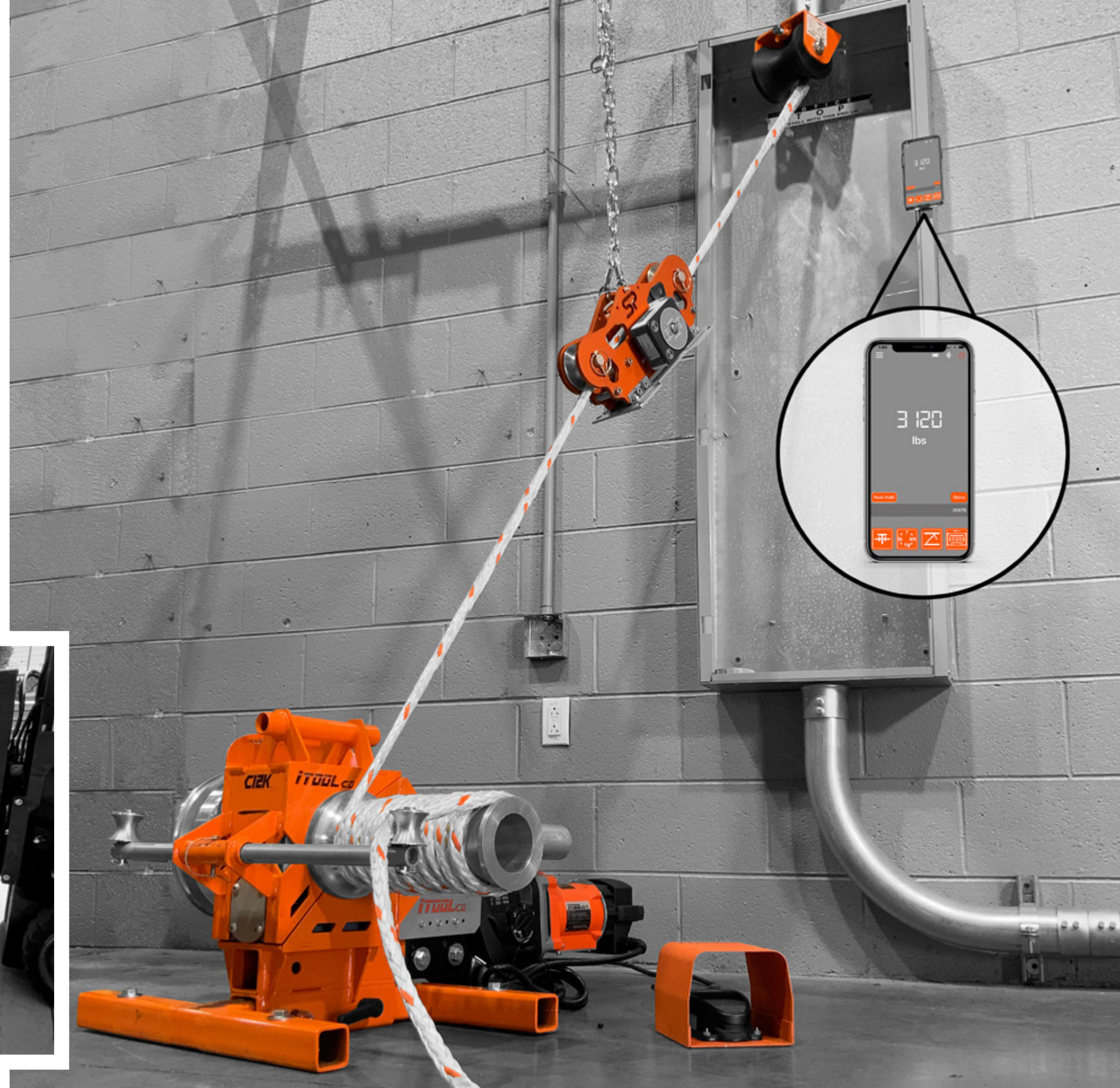

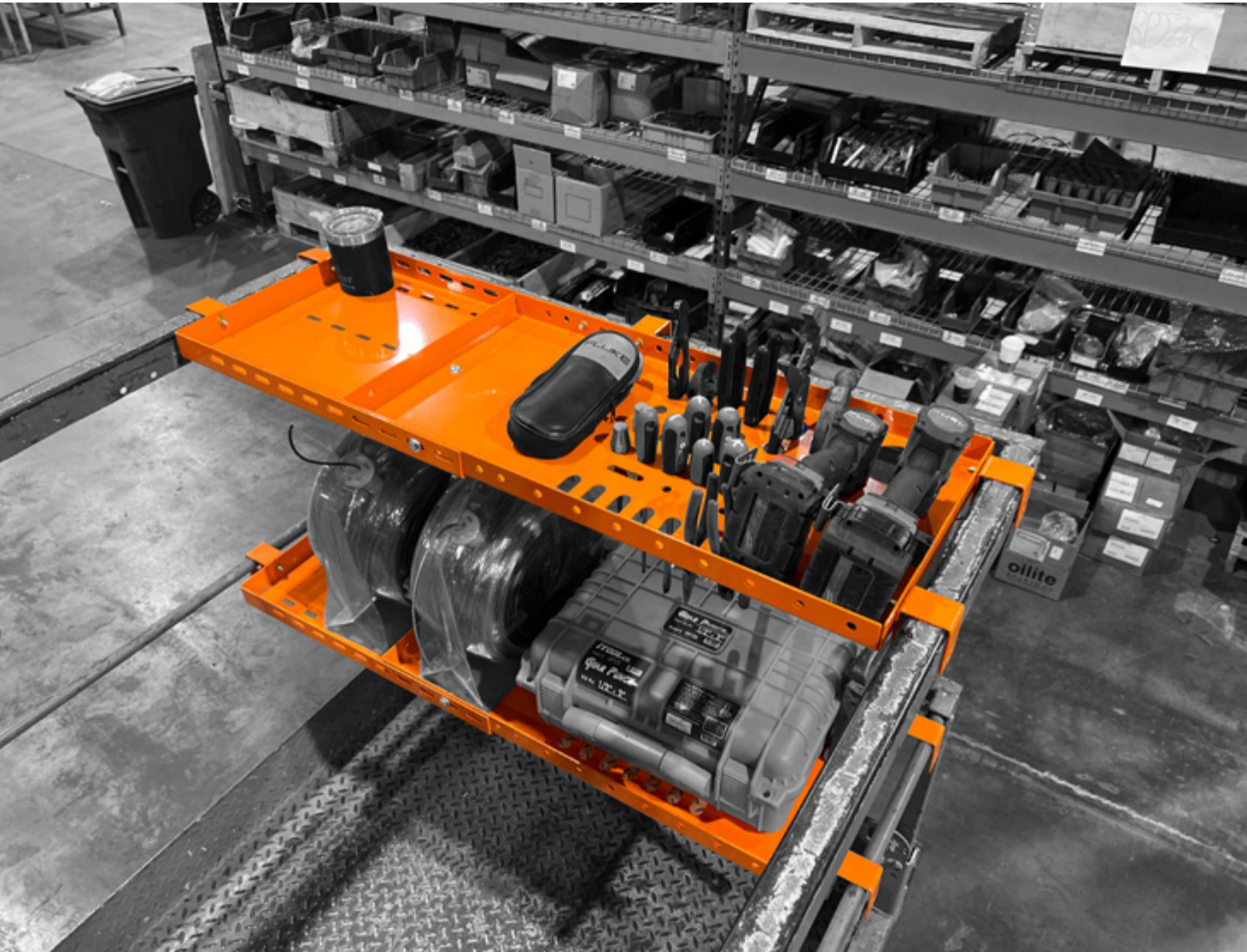

As well as their Cordless Cannon 3K & 6K (the first on the market of each, respectively). Capable of reaching areas where power may not be available, these pullers allow users to achieve the same amount of power, without worrying where it will come from. More recently the launch of their MVP20K has changed the game for large pulls, making quick work of even the toughest setups. With an output torque limit dial capable of setting load limits. A fully hydraulic adjustable arm setup, and the ability to bring power wherever you need it – the MVP20K is perfect for jobs too big for even the 12K. Also known for their Gear Punch which includes lifetime replacement on draw studs, Tray Rollers, numerous Material Handling

solutions, etc. iTOOLco ensures that no matter the job, there is a solution. Over the years iTOOLco has had their sights set on being leaders of innovation in the industry and 2023 will be no different. With a goal set to launch one new product every week – there is an absolute push to break boundaries and set precedent within the industry as a standard for how new products should improve work conditions. With the scheduled release of so many new products, iTOOLco's core value of creating a Faster Safer Workspace has never been more clear. By centering focus on their 30/30 program, they hope to influence customers to take a more serious look into material handling solutions – where there is usually a lot

of money left on the table due to poor time & material management. The 30/30 program challenges this standard, instead pushing the idea of keeping all materials within 30 feet or 30 seconds of the area you're working. With the release of countless new material handling solutions, iTOOLco is looking to change the way contractors approach day to day operations. iTOOLco is also looking to expand their reach further into other markets. With its rollout of several utility focused wire pullers, carts, and pulling carrots. They hope to push their vision of innovation into the utility market and offer a variety of solutions designed to make simple but effective changes to the way utility contractors go to work.



Redefine roadway performance

Introducing RoadMax.
Evluma's next generation roadway luminaires deliver uncompromising performance and industry leading glare control. Because essential roads deserve exceptional light.



RoadMax™
by **evluma**

evluma.com | sales@evluma.com



The iTOOLco production team has gone above and beyond to keep up with increasing demand during a time where lead times seem to only grow longer. Owners and Co-Founders David & Michael Jordan credit this to making their products in America. “Being able to walk out into the shop every day and lay eyes on the product and have my thumb on what is going on is critical,” said David. David and Michael take great pride in building their team – with the belief a good team is the core of the company. By creating a demo style that changed the way live demos were approached – the iTOOLco sales team creates an interactive experience for its customers. “We have the best sales team in the industry, hands down.” Says

Michael – who has spent countless hours in the field himself ensuring the team has the best person to person training to meet customer needs. With a fully equipped demo trailer, the team travels the country from state to state – providing an in-depth product breakdown and training wherever they are needed. Wanting to make sure all aspects of customer care are taken to the highest level, iTOOLco approaches servicing their tools with a different mindset – easy communication & a fast turnaround time. Coming in from the start with an industry leading 6-year warranty, and a service team that not only is responsive – but truly understands that there is a person at the other end of the call was

imperative. With a regular turnaround time of within a week, from shipment of your item to the warehouse and back to you. The service team is determined to get your product back to you as soon as possible. “We understand things happen, and we will do our best to fix the issue and get your tool back to you as fast as possible” said Maria Jordan – head of customer care. “Service to our customers has always been held to a higher standard and that won’t stop anytime soon.” Reaching out to iTOOLco for a quote has also never been easier. “With our new “add to quote” feature – customers can build their package and get a quote the same day, usually within an hour. Our inside sales team will also provide



Extend Luminaire Life While Reducing Energy Consumption

The Appleton™ Mercmaster™ Connect LED by Emerson is designed to illuminate hazardous and harsh industrial locations with integrated motion and illuminance sensors. Paired with Emerson’s Plantweb Insight Connected Lighting Application, operators have access to lighting usage data and sustainability analytics.



Appleton™ Mercmaster™ Connect LED

The Mercmaster Connect LED provides facility managers with continuous monitoring of their LED lighting with real-time insights gained into sustainability goals, diagnostics and lumen levels from any remote location at dramatically lower costs as compared to wired alternatives, with faster installation time and minimal disruption to plant operations.

Learn more at: masteringled.com

APPLETON

The Emerson logo is a trademark and a service mark of Emerson Electric Co. © 2021 Emerson Electric Co.

EMERSON

CONSIDER IT SOLVED™



them with their closest distributor and connect them. As well as answer any questions they have about the products they are interested in” said Calvin Jordan – Director of Marketing. “Connecting with our customer base is crucial to our success, and we want to make the process as easy as we can for them. The new site allows customers to

easily take 360 spins of the products, access cut sheets, product videos, and much more.” iTOOLco also releases several promotions a month – offering a pre-specified amount in free tools for your purchase. (Contact for more details) If you are interested in keeping up with iTOOLco, follow us on our

socials @itoolco on any platform, there we keep you updated on our latest innovations. You can also keep up by going to the bottom of our website and signing up for our newsletter. Want to find out more or schedule a live demo? Visit our website at www.iTOOLco.com or give us a call at 865-670-3713. □



Lighting Your Way at Greater Heights

The Appleton™ IHC LED Luminaire by Emerson is the ideal solution to deliver light from mounting heights of 50 to over 100 feet. With outputs up to 90,000 lumens, an IP66 marine and wet location rating, and an ambient temperature range of -40 °C (-40 °F) to 75 °C (167 °F), the IHC was designed to meet the demands of your harsh industrial environment and lighting requirements.

Learn more at: masteringled.com

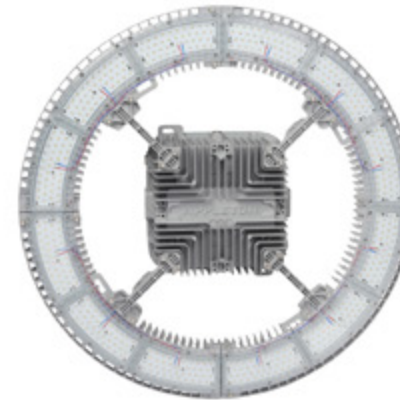

Appleton™ IHC LED Luminaire

APPLETON

The Emerson logo is a trademark and a service mark of Emerson Electric Co. © 2021 Emerson Electric Co.

EMERSON

CONSIDER IT SOLVED™

Fluke donates tools to the Lee College instrumentation lab in memory of long-time Fluke engineer Bob Greenberg

Donation of 75 tools honors “the Godfather of Clamp Meters”

Fluke Corp. has donated 75 tools to Lee College in honor of long-time Fluke engineer Bob Greenberg, who passed away in February 2022. Greenberg, who was considered the “Godfather of Clamp Meters,” served as the product planner for clamp meters as well as the 50 Series Digital Thermometer. In his more than 30 years in the Fluke engineering and product planning groups, he exemplified customer care and understanding customer needs.

“Bob’s passion for Fluke tools and technology may have only been matched by his enjoyment in sharing his product and industry knowledge with his colleagues, peers, team, and the education community,” said [name and title] for Fluke Corporation. “While Bob will be sorely missed, the impact and legacy he leaves will resonate with the Fluke community for years to come.”

Headquartered in Baytown, Texas, Lee College serves its community by providing innovative and quality education to its diverse students along guided pathways to gainful employment, personal enrichment, and life-long learning. It is home to one of the top 10 instrumentation programs in the country and has built a strong school-to-work pipeline supporting the workforce/skills shortage challenges. Many of its graduates work for leading oil, gas, and automation companies in the United States.

“We are grateful for Fluke’s donation of tools to our instrumentation lab not only because it helps our students learn, but because it honors the legacy of Bob Greenberg, who was an inspiring leader in the industry,” said Davoud Khoini, technical studies division chair at Lee College. “The donation of Fluke technologies allows us to upgrade our instrumentation lab with the latest tools enabling our students get hands-on experience with real-world equipment so they can prepare to enter the workforce after they complete their studies.”

While Greenberg retired from Fluke more than a decade ago, he remained an active volunteer in the company’s charitable activities, including:

- Fluke’s Tool Donations program, which provides hundreds of refurbished Fluke tools to numerous non-profits, universities, colleges, trade schools and union apprenticeship programs across the United States;
- Distribution of tools for natural disaster relief efforts; and
- Co-organizing the Annual Employee Holiday Sales Event each December.

For information on Fluke tools and applications, or to find the location of a distributor, contact Fluke Corporation, P.O.



Greenberg, who was considered the “Godfather of Clamp Meters,” served as the product planner for clamp meters as well as the 50 Series Digital Thermometer. In his more than 30 years in the Fluke engineering and product planning groups, he exemplified customer care and understanding customer needs.

Box 9090, Everett, WA USA 98206, call (800) 44-FLUKE (800-443-5853), fax (425) 446-5116, e-mail fluke-info@fluke.com or visit the Fluke Web site at www.fluke.com. □

ABOUT FLUKE

Founded in 1948, Fluke Corporation is the world leader in compact, professional electronic test tools and software for measuring and condition monitoring. Fluke customers are technicians, engineers, electricians, maintenance managers, and metrologists who install, troubleshoot, and maintain industrial, electrical, and electronic equipment and calibration processes.



Versatile Mounting for Extreme Environments

The SolaHD™ SCP-X Series Standalone IP67 Power Supplies by Emerson can be mounted almost anywhere on a machine, conveyor, or wall. With no enclosure required they offer safety against arc flash hazards.

Quick-connect cables ensure the IP67 rating and eliminate costly wiring. Available from 100 Watts to 240 Watts, the SCP-X Power Supplies meet the diverse needs of automotive manufacturing, conveyor systems, and equipment where 24 Vdc power is required for geographically dispersed devices.

Learn More at: www.solahd.com



SolaHD™ SCP-X Series Standalone IP67 Power Supplies

SOLAHD™

The Emerson logo is a trademark and a service mark of Emerson Electric Co. © 2021 Emerson Electric Co.



CONSIDER IT SOLVED™

NSI Industries Moves Into New HQ

152,000 Square Foot Facility Triples the Size of NSI's Previous Headquarters and Distribution Center New D.C. Houses All NSI Brand Products; Streamlines Warehousing and Shipping Operations

NSI Industries, LLC, a leading provider of electrical, HVAC, and building technology product solutions for more than 45 years, has announced that it has moved into its new corporate headquarters, also in Huntersville, N.C. The new 152,000 sq. ft facility, two-and-a-half times the size of NSI's previous building, is also home to its new, state-of-the-art warehouse and distribution center. The new facility is more than three times larger than its old space, creating additional capacity to serve more customers.

"As NSI has continued to expand with its recent acquisitions the past couple of years, we needed a new home that would allow us to consolidate all of our brands' warehousing needs into a new, more modern and streamlined corporate and distribution operation," explained G. R. Schrottenboer, CEO of NSI Industries. "The investment in the new facility reflects the company's recent exponential growth. We've been in Huntersville since our founding, and our employees are considered family. As such, we developed a plan that would allow us to create a brand new HQ from the ground up that is not only centrally located for our employees but would also allow us to create a better employee experience to our exacting standards and precise specifications."

As part of the employee experience, the new facility includes a larger, more open office with inviting spaces for collaboration, conference rooms for group meetings and 1:1 meetings, a noise-dampening system to help staff focus on the tasks at hand, the latest technology for virtual and in-person meetings, recycling areas, a bright break room, covered outdoor patio, easy access to walking paths, bike lanes throughout the business park, bike racks on campus, and a locker room with showers.

The new headquarters is also home to lab space as well as quality control and new product development departments. With confidence in all of its electrical, building technology, and HVAC market products, NSI ensured that as many of its' brands' products were used to build the new facility, including those from Bridgeport Fittings®, Polaris® Power Connectors, TORK®Timers and Controls, WarriorWrap® Professional Tape, TERMINATOR™ Premium Wire Connectors, RHINO



G.R. Schrottenboer, NSI CEO; Margaret Thornton, Associate Director at The ROC Charlotte; Jim Piazza, NSI VP of Marketing



Jim Piazza, NSI VP of Marketing; Natasha Marcus, NC Senator District 41; G.R. Schrottenboer, NSI CEO; Bill Russell, President & CEO of Lake Norman Chamber of Commerce

Safety™, Platinum Tools®, TechLogix Networkx, Duro Dyne® Sheet Metal Accessories, Metallics™ Fasteners, Remke Industries, and Lynn Electronics.

"Creating one HQ and distribution center for all of our brands has allowed us to consolidate seven locations into one," Schrottenboer continued. "Efficiency was our goal. We can now drastically accelerate shipping by streamlining the ordering, packaging, and distribution processes with modern, up-to-date warehouse and distribution technologies. Also, we are making progress toward our new 'one order – one invoice' method enabling customers to order multiple NSI brands on one order, receive one invoice and in many cases one shipment.." □

ABOUT NSI INDUSTRIES, LLC

NSI's core philosophy is Making Connections. Focused on the electrical, building technology, and HVAC markets, NSI connects distributors to products, services, and technologies by providing a fresh perspective and caring approach that drives smart solutions. The driving force behind a stable of market-leading brands and a large breadth of products, the company's primary job for more than 45 years has been to fulfill the needs of distributors and their customers. By staying grounded in the principles of service and value, NSI continues to deliver high-quality, industry-advancing, and comprehensive product solutions that enable growth.



NSI has many well-respected brands, including Bridgeport Fittings®, Polaris® Power Connectors, TORK®Timers and Controls, WarriorWrap® Professional Tape, TERMINATOR™ Premium Wire Connectors, RHINO Safety™, Platinum Tools®, TechLogix Networkx, Duro Dyne® Sheet Metal Accessories, Metallics™ Fasteners, Remke Industries, and Lynn Electronics. For additional information about NSI Industries and our family of brands, visit www.nsiindustries.com.

SP PRODUCTS, INC.

Productivity and value thru ideas

FOR SAFER BETTER FASTER JOBS

We're Proud to be the Electricians' Friend for Over 50 Years!

IP15a

Chamfer Bit
for PVC SCH 40/80

PATENT PENDING

Smooth Beveled Edge after Chamfering

IP27b

Electro Post EP-10
Box Support Bracket

Mounts on all standard stud widths of 2-1/2", 3-5/8" or 6"

PATENT PENDING

IP15b

Chamfer Bit
for Aluminum EMT

PATENT PENDING

Smooth Beveled Edge after Chamfering

NEW PRODUCTS

4-WAY CONDUIT & BOX SUPPORT PLATE with Split Fingers for Horizontal or Vertical Installation

Use 4-Conduit Block (IP19 or IP20) with QwikBlock (IP21a)

IP19/20

4-Conduit Block

PATENTED

IP21a

QwikBlock

PATENT PENDING

PVC Running Thread SCH 40/80 Up to 30" Long

PATENT PENDING

IP3d

NEW Transition Fittings

Saves a Great Deal of Time Repairing Conduit

The Inside Diameter Remains the Same

Allows for Trouble Free Wire and Cable Pulls

IP13p

3/4" MC Cable to PVC

PATENT PENDING

IP13k

Inside PVC to Inside PVC

PATENT PENDING

IP13q

PVC Reducer

PATENT PENDING

Male Threaded PVC Offset

IP3c

1/2" thru 3" Offset for Conduit Sizes 1/2" thru 6"

PATENT PENDING

Plus More Being Invented for SAFER BETTER FASTER Jobs . . . Call With Your Ideas!

- + Rise Higher
- + Go Farther
- + Shine Brighter
- + Work Smarter

The New 100W OmniMax

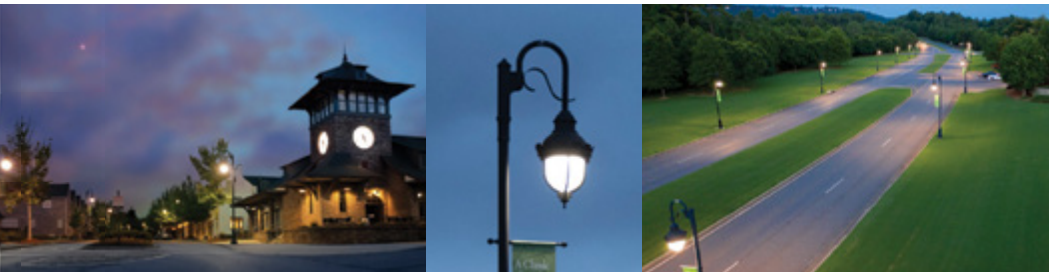

More light. Dependably beautiful.
With light output competitive to a 150W HID, you get more lumens, across a broader range of applications, without compromising light quality.

You asked, and we delivered. The 100W OmniMax LED retrofit was designed specifically for applications where you need more light from your decorative fixtures, such as taller pendant and teardrop applications (>25'), and locations where decorative luminaires are the primary light source.

A new patented Evluma driver delivers higher lumen output, even at lower CCT levels. Pair that with OmniMax's revolutionary low-glare optics, and you get the kind of light your decorative fixtures were built for: warm, beautiful and bright.

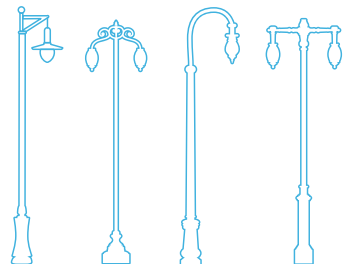

evluma

RANDL
INDUSTRIES, INC.

Install Peace of Mind!

First there was 4 square...
and now the **REVOLUTIONARY 5 Square® Box!!**

You've struggled with 4 Square boxes for years - you know how small, cramped and time consuming they are. Finally, there is a solution that allows you the space you have always needed.

The **5 Square®** Boxes (5" x 5" x 2-7/8") provide up to 88 in³ of interior volume which more than doubles that of most existing boxes on the market.

Create a robust and unrivaled infrastructure for the life of your facility with the **5 Square®** Products!



Fire Signal



- TWICE THE VOLUME AS MOST BOXES
- SAVE LABOR...INCREASE PROFITS
- ELIMINATES TROUBLESHOOTING TIME AND COST
- FULLY UPGRADEABLE SYSTEM
- SPECIFIED BY ENGINEERING FIRMS, HOSPITALS, UNIVERSITIES & GOVERNMENT AGENCIES
- AVAILABLE IN ZINC OR RED

Telecommunications



- INTEGRAL CABLE MANAGEMENT
- SAVE LABOR...INCREASE PROFITS
- FACILITATES MIN. BEND RADIUS REQUIREMENTS
- SUPPORTS CURRENT AND EVOLVING SYSTEMS
- SUPPORTS PoE PLUS
- SPECIFIED BY ENGINEERING FIRMS, HOSPITALS, UNIVERSITIES & GOVERNMENT AGENCIES

RANDL
INDUSTRIES, INC.

P: 509.340.0050 • F: 509.340.0051

See our line of telecom & fire signal boxes at: www.RANDL-INC.com

Making Communications & Fire Protection More Reliable & Cost-Effective!

EasyHeat Sno*Melter Mats Pave the Way to Safer, Slip-free Sidewalks this Winter

Versatile, heating mats install under driveways, sidewalks, patios and more, melting snow and ice to prevent accidents

According to the U.S. Centers for Disease Control and Prevention, approximately 1 million Americans are injured annually as the result of falling on ice and snow. Tragically, these injuries are fatal for about 17,000 people every year.

Prevention is the key to avoid being injured in a winter fall accident. EasyHeat® is helping keep all of us out of harm's way with its Sno*Melter® mats. Simple to install, energy-efficient and environmentally-friendly, these dual-conductor mats provide reliable snow melting for driveways, sidewalks, patios and stairs. By melting ice and snow before it accumulates, Sno*Melter® mats eliminate the need to shovel, snow-blow or spread environmentally harmful chemicals. SnoMelter mats keep walkways as safe to travel on in winter as they are in the summer.

Installed underneath concrete, asphalt or pavers, EasyHeat Sno*Melter® mats are the simplest and safest method of fall protection. When combined with an EasyHeat controller (sold separately), Sno*Melter mats automatically maintain a surface temperature above freezing. In most cases, causing snow to melt, plus prevent ice from forming on the heated surface. Loading docks, ambulance entries and passenger platforms at bus stations and train depots also benefit from Sno*Melter protection where pedestrians can move securely on the protected surface.

Sno*Melter Mats are available in sizes that cover from 7.5 to 90 square feet using just a single mat. Depending on the voltage available and configuration, mats can easily be combined and tailored to cover a unique walk, stair, patio and driveway configuration. Mats are engineered to provide 538 Watts per square meter (50 Watts per square foot) and are supplied with 6 meters (20 feet) cold leads. Custom step mats are available for nonstandard power densities up to 800 Watts per square meter (75 Watts per square foot), voltage, cold lead lengths and size needs. Properly installed, mats normally provide trouble-free service as long as the pavement or concrete in which they are embedded is not disturbed or damaged.

Ice, snow and sleet make staying on two feet a challenge for people of any age. Now is the right time to install EasyHeat Sno*Melter® mats — before the first snowfall comes.



For more information, visit
www.easyheat.com

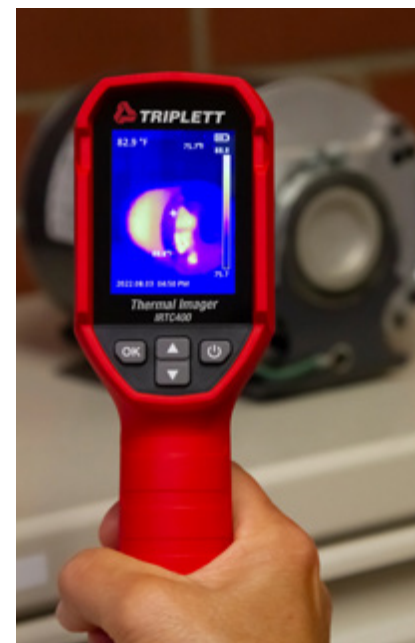

Triplet Highlights IRTC400 Thermal Imaging Camera

Identifies leaks and hot spots in electrical, HVAC, automotive, and facility applications

Triplet Test Equipment, a leading maker of test equipment tools, highlights the IRTC400 Thermal Imaging Camera, ideal for finding leaks and hot spots in electrical, HVAC, automotive, and facility applications.

The thermal imager has a 120 x 90 pixel (10,800) thermal detector with ≤60mk Thermal Sensitivity (NETD) that displays both center spot and high/low temperature tracking. The imager's sensors allow it to detect mechanical breakdowns, water leaks and moisture buildup, heat loss from missing insulation and faulty windows/doors, and more. The 2.4" (61mm) focus-free, color TFT display shows imagery in 320 x 240 resolution with multiple color display palettes including Ironbow, Rainbow, White-Hot, Black-Hot, Rainbow HC, and Lava.

The imager has a temperature range of -4 to 752°F (-20 to 400°C), a built-in LED worklight, and user programmable audible and visual high/low temperature alarms, making the imager customizable and ready for use in any environment. The on board-image gallery allows users to view images (.bmp) on-site or transfer them to a PC via USB interface.

Additional features include an easy-to-use 4-button menu, auto power off with disable, a real time clock/calendar, 3.7V rechargeable Lithium Ion battery, and a 1-year warranty.

For more information, visit
<https://triplett.com/online>



Compact and Easy to Install DC UPS for Harsh Industrial Locations

The SolahD™ SDU DC - B Series DIN Rail UPS by Emerson are perfect for mitigating power quality issues, minimizing loss of data and downtime.



SolahD™ SDU DC - B Series DIN Rail UPS

The SDU DC - B UPS combines an industry leading compact design, wide operation temperature range -15 °C to +50 °C (+5 °F to +122 °F), enhanced communication and unique installation options to solve common application problems.

Learn more at: www.solahd.com

SOLAHD

The Emerson logo is a trademark and a service mark of Emerson Electric Co. © 2021 Emerson Electric Co.



CONSIDER IT SOLVED™

Milwaukee Tool Continues to Light the Site with a New Lighting Solution with PACKOUT™ Compatibility

Milwaukee® continues to provide innovative lighting solutions for the jobsite with the addition of their latest lighting solution, the M12™ PACKOUT™ Flood Light w/ USB Charging. The new lighting solution delivers users with maximum light output in a compact and mobile design that is top stack compatible with the PACKOUT™ Modular Storage System.*

The M12™ PACKOUT™ Flood Light w/ USB Charging delivers 1,400 lumens of TRUEVIEW™ High-Definition Output* and features three different modes, allowing users to manage the light output and run-time, depending on the needs of the job. When paired with an M12™ XC 4.0 battery pack, the light provides up to 12 hours of runtime. The M12™ PACKOUT™ Flood Light w/ USB Charging is designed to be top stack compatible with all PACKOUT™ solutions, making it easily accessible and increasing productivity on the site. Turned on or off, the PACKOUT™ light can be used on any existing PACKOUT™ stack.

The PACKOUT™ Light comes with a 2.1AMP USB-A and USB-C port to charge devices and features two storage compartments to organize small items inside. The light head can rotate 300 degrees horizontally and 180 degrees vertically, offering complete light head control.

Built to withstand the toughest conditions, the PACKOUT™ Light is IP54 rated for dust and water resistance. The light will be a part of Milwaukee Tool's 5-Year Warranty, while also including Limited Lifetime LED Warranty.

The new M12™ PACKOUT™ Flood Light w/USB Charging joins the M12™ Cordless System, the largest sub-compact system on the market, focused on delivering industry-leading durability and power in the tightest spaces. Currently, the M12™ System is made up of more than 100 solutions.

*TRUEVIEW™ Technology and optical design delivers a consistent beam, optimized color temperature, and true representation of colors and detail leading to a more productive work area.

**The PACKOUT™ Modular Storage System is the most versatile and durable modular storage system in the industry. An intuitive and quick attachment mechanism gives users the freedom to stack and lock PACKOUT™ tool boxes, organizers, totes, and bags of different sizes in numerous configurations that best suit their needs.



For more information, visit
www.milwaukeetool.com

Russelectric, A Siemens Business, Highlights the External Manual Operator (E.M.O.) on Automatic Transfer Switches

Unique design enables easy, safe, and quick manual transfer with the door fully closed

Russelectric, A Siemens Business, a leading manufacturer of power control systems and automatic transfer switches, highlights the External Manual Operator (E.M.O.), a standard feature of the Russelectric® RTS-03 Series and RTS-30 Series of open-transition automatic transfer switches, the most rugged and complete line of 480 VAC 30-cycle and 3-cycle UL tested switches available in the market today. The unique External Manual Operator feature enables easy, safe, and quick manual transfer with the door fully closed, significantly reducing downtime and the risk of arc flash injuries.

With the External Manual Operator, the manual transfer process is much easier and faster for both the preferred and the alternative power sources, and no special procedures are required to ensure the system is de-energized during the transfer operation. That means less downtime because the cabinet door remains closed.

The External Manual Operator utilizes the same Russelectric transfer mechanism as the automatic electrical operator, a design proven to provide exceptional safety and durability. During an open-transition transfer, the contact mechanism is securely locked in position until an over-center position is reached. Preloaded springs then instantaneously open the closed contacts (quick-break) and instantaneously close the open contacts (quick-make) with only a momentary break in between.

This quick-break design along with rapid arc quenching features provide for rapid arc interruption, under maximum voltage and amperage, reducing contact erosion and overheating to extend useful life. Russelectric transfer switches have the highest 480 VAC 3-cycle closing and withstand ratings of any switches available today.

For more information, visit
<https://new.siemens.com>



“When Disasters Strike, First Responders Rely On Us!”

Our complete control, communication and convenience Utility Truck Console is becoming the new standard for truck fleets of all sizes. Loaded with standard and optional features that maximize ergonomics, productivity, and fleet/telecom standards into a one exceptional Mobile Console Solution.



MOBILE DESK
MOBILE OFFICE SOLUTIONS
1-877-663-3375
www.mobiledesk.com

Copyright © 2022 Mobile Desk, LLC. All Rights Reserved.



Transition Couplings

PVC Bell End Adapter

Galvanized Rigid Conduit

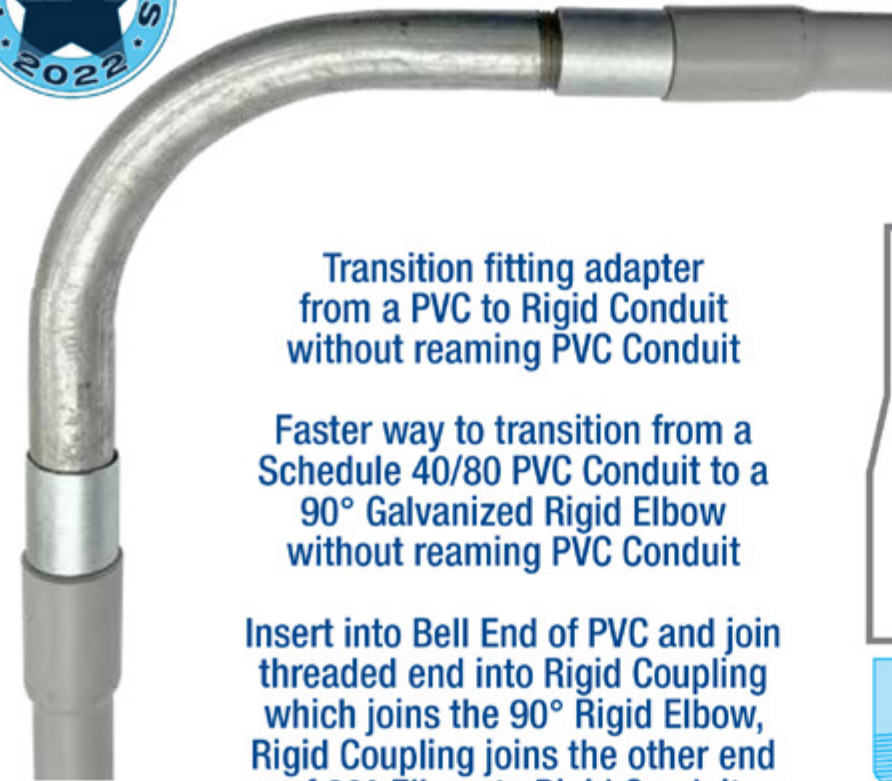

UL US
 PATENT PENDING



Transition fitting adapter from a PVC to Rigid Conduit without reaming PVC Conduit

Faster way to transition from a Schedule 40/80 PVC Conduit to a 90° Galvanized Rigid Elbow without reaming PVC Conduit

Insert into Bell End of PVC and join threaded end into Rigid Coupling which joins the 90° Rigid Elbow, Rigid Coupling joins the other end of 90° Elbow to Rigid Conduit

Meets UL651 CSA CSS.L Ng83 and US Army Corps or Engineers Specs.



PVC Conduit Bell End



PBEA RGD



Rigid Coupling

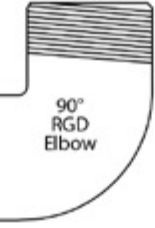

90° RGD Elbow

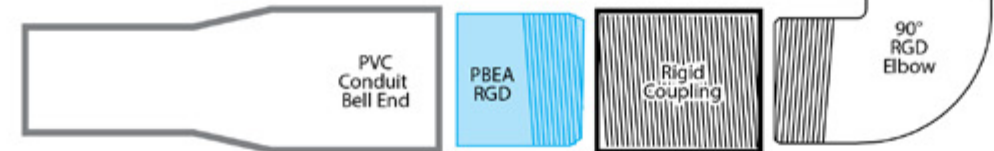

PVC Conduit Bell End

PBEA RGD

Rigid Coupling

90° RGD Elbow

1/2" thru 6"

Transition Couplings	
Size	Catalog #
1/2"	PBEA/RGD 50
3/4"	PBEA/RGD 75
1"	PBEA/RGD 100
1-1/4"	PBEA/RGD 125
1 1/2"	PBEA/RGD 150
2"	PBEA/RGD 200
2-1/2"	PBEA/RGD 250
3"	PBEA/RGD 300
3-1/2"	PBEA/RGD 350
4"	PBEA/RGD 400
5"	PBEA/RGD 500
6"	PBEA/RGD 600

2022 **NECA**
Show Stopper
 WINNER

Customer must satisfy all codes and owners' specifications.



PATENT PENDING
 PATENTED



LABELS APPLY TO PRODUCTS ONLY WHERE SHOWN ABOVE

new
PRODUCTS

Dynamic® Offers New Line of Tool Organizers for Sockets, Wrenches and More

The Dynamic® tool brand has introduced a new line of tool organizers. The line includes several convenient solutions for storing sockets, wrenches, screwdrivers and other small tools. Manufactured with industrial quality and offered at budget-sensitive prices, each Dynamic tool organizer comes with a lifetime warranty, which is backed by Gray Tools, the well-respected North American hand tool manufacturer.

Dynamic's offering includes three types of socket organizers to accommodate various needs. First, the magnetic socket organizer securely stores sockets in an upright position. Complete with magnetic base, the organizers are available in red for SAE and blue for metric sockets, and they have sizes clearly printed on them for easy identification and selection. The next product is a socket organizer tray, which features a slim profile design for placement within shallow toolbox drawers. It uses magnets to hold sockets in place and comes with stickers for size labeling of each of socket held. The third product is an aluminum socket organizer rail, which includes clips with spring-loaded bearings to hold up to 20 sockets in place.

All three socket organizers are compatible with most regular and deep chrome sockets, as well as impact sockets. Options are available to accommodate 1/4", 3/8" and 1/2" drives in both SAE and metric sizes.

Also available from Dynamic is a two-piece wrench holder, which can accommodate most regular-length combination, open-ended and ratcheting wrenches. The organizers are color-coded for SAE and metric wrenches, and they hold up to 15 wrenches each. A slim profile allows the holders to be stored in shallow toolbox drawers, while a handle and mounting holes provide hanging options.

Finally, Dynamic offers a magnetic screwdriver and small tool organizer, which uses 16 high-tension clips to securely hold screwdrivers, as well as wrenches, ratchets, extensions and other small tools. It has a strong magnetic base, allowing it to be mounted on various steel surfaces.



**For more information, visit
ShopDynamicTools.com**



Klein Tools® Launches New VACO Line of Step Drill Bits

Klein Tools, for professionals since 1857, introduces VACO Step Drill Bits and Kits, a line of drill bits with comparable features to other drill bits on the market but at a competitive price point.

VACO Step Drill Bits and Kits

- Dual spiral flutes to remove chips and help pull the bit through material for faster cutting
- Titanium nitride (TiN) coating dissipates heat for longer bit life
- 1/4-Inch hex shank for firm, positive grip in impact driver and standard drill

- Split point tip quickly starts hole cuts and prevents drifting when pressure is added
- Laser-etched hole size markings for quick size identification
- For use on steel (up to 16 gauge), plastic, aluminum & wood
- All Purpose Kit (Cat. No. 25950) has a total of 37-hole sizes and is great for cutting holes in a wide variety of DIY applications and materials (steel, plastic, aluminum, wood) – Includes: Cat. Nos. 25960, 25962, 25963 & 25964
- Electrician's Kit (Cat. No. 25951) has a total of 17-hole sizes and is perfect for creating hole cutouts in panels and j-boxes to accommodate most commonly used 1/2, 3/4 and 1-Inch conduit – Includes: Cat. Nos. 25960 25961 & 25962
- Kits come with a 1-ounce oil bottle for bit lubrication and longevity
- Durable, hard case nests bits and oil bottle

"Across various trades, professionals have the need for high quality tools at an affordable price point," says Amina Nunn, product manager at Klein Tools. "With Klein's new line of VACO Step Drill Bits, professionals can find just that. These Bits feature double spiral-flutes, TiN coating and are compatible with both standard drills and impact drivers. All of this paired with their competitive price make them perfect for everyone, from DIY enthusiasts all the way up to professionals."

**For more information, visit
www.kleintools.com**

The Heavy Duty Nonmetallic CABLE RACK

For Power and Communications Manholes And Vaults

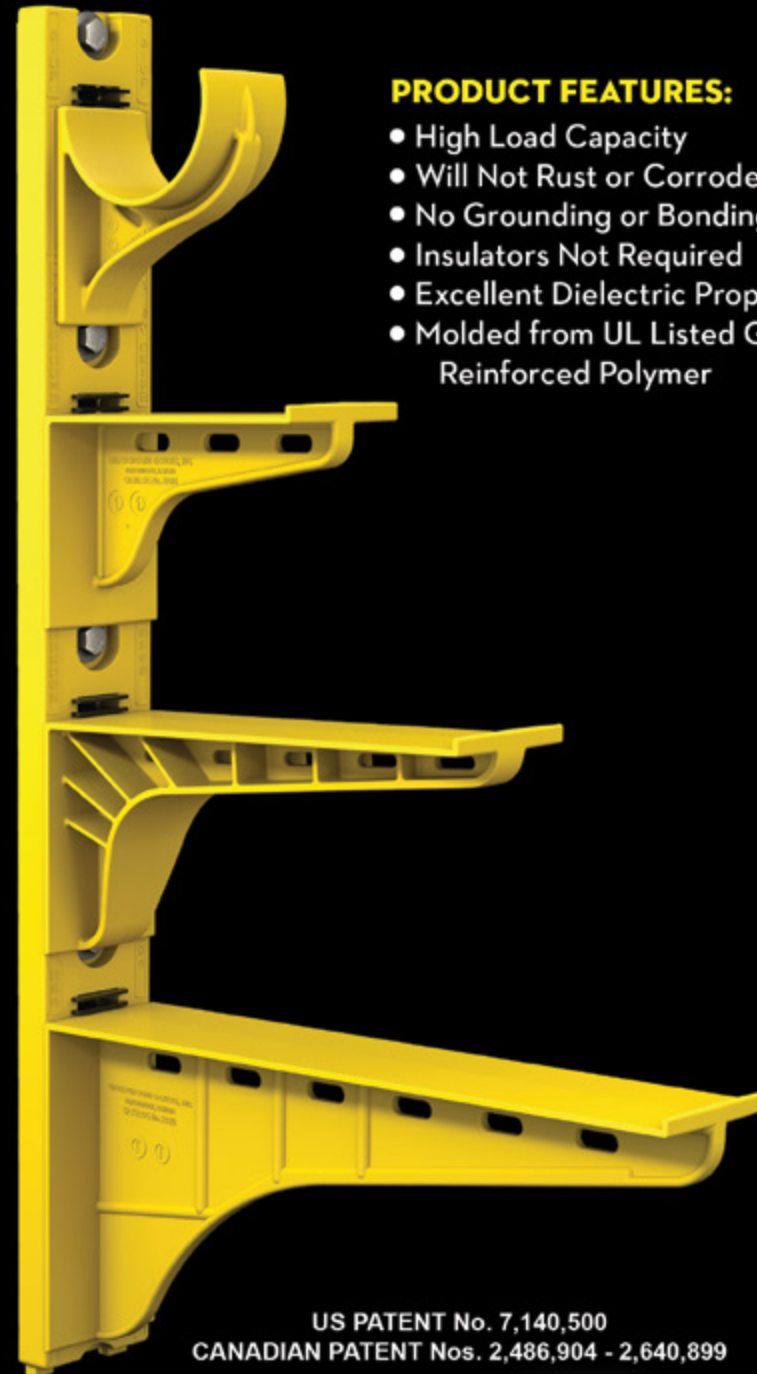

US PATENT No. 7,140,500
CANADIAN PATENT Nos. 2,486,904 - 2,640,899

PRODUCT FEATURES:

- High Load Capacity
- Will Not Rust or Corrode
- No Grounding or Bonding
- Insulators Not Required
- Excellent Dielectric Properties
- Molded from UL Listed Glass Reinforced Polymer



HDL Arm Lock shown with RA04 Arm and CR36-B Stanchion



3HDS - 3" throat saddle shown with a cable secured by cable ties.



RA08 - 8" arm shown with three cables secured by cable ties.

UNDERGROUND DEVICES
INCORPORATED



420 ACADEMY DRIVE
NORTHBROOK, IL 60062
Phone: 847-205-9000 • Fax: 847-205-9004
Website: www.udevices.com

Emerson Expands Appleton Rigmaster™ LED Linear Luminaires Line

Low-Profile, Lightweight LED Industrial Lighting Available for Explosionproof, Hazardous and Ordinary Locations with Optional Emergency Battery Backup



Originally engineered for land-based drilling rigs, Emerson has expanded its line of Appleton Rigmaster LED linear luminaires to bring the fixture's low-profile, lightweight and energy-efficient design to new lighting applications. Appleton Rigmasters are now available for explosiveproof, hazardous and ordinary industrial locations, making the luminaires suited for underground tunnels, foundries, warehouses, and food processing plants, among other locations where dirt, dust and moisture are a problem.

No matter where they are installed, Appleton Rigmaster LED linear luminaires furnish high-visibility lighting output up to 8000 lumens, while reducing annoying shadows and glare to achieve safer, more productive work environments for employees. Precision engineered clear polycarbonate lenses yield wider light distribution for greater area coverage to reduce the number of fixtures needed to be installed.

The Appleton Rigmaster line is comprised of three versions: An explosionproof model for Class I, Division 1 locations, a hazardous location luminaire for Class I, Division 2 areas, and an industrial, ordinary location version. An optional emergency battery backup provides up to 180 minutes in safety lighting. All three solutions meet IP rating requirements as being both "dust tight" and impervious against powerful jets of water, as well as NEMA certified for wet and marine areas.

When compared to conventional T8 fluorescent fixtures, Appleton Rigmaster LED linear luminaires consume less than half the energy, reduce maintenance and replacement costs, plus turn "on" instantly without warm-up, while helping the facility minimize its carbon footprint. Also, the LED life of 60,000+ hours means years of maintenance-free operation, unlike fluorescents that may fail in six months or less and require frequent maintenance.

Appleton understands that electricians prefer luminaires that install fast and easy. The Rigmaster meets these requirements by integrating LED technology into a very lightweight, low-profile package. Every element of its design promotes streamlined, hassle-free deployments and maintenance. For example, its mounting brackets accommodate most bolt patterns for other luminaire manufacturers when retrofitting older fixtures. Its hinged wiring compartment is secured with captive screws to prevent the screws from dropping to the floor below. Two NPT hubs on each end of the fixture allow for simple through wiring. Leads are also placed outside the wiring compartment so the installer can bypass the screw cover. Two mounting options are available — yoke brackets and a pendant kit— for added location flexibility. Installers can even choose between using Wirenuts or screw terminal blocks in the 120-277 Vac configured models.

Due to high vibration machinery in industrial plants, secondary retention of a light fixture is a priority in preventing it from plunging from a high-rise mast. Rigmaster LEDs feature a looping safety cable through the fixture and around the mounting structure that secures it from falling onto employees or equipment.

For more information, visit www.MasteringLED.com

DEWALT Launches FLEXTORQ® Square Drive Modular Right Angle Attachments

Redefine accessibility with new FLEXTORQ® Square Drive Modular Right Angle Attachments. Available in either a 1/4" (DWAMRA14FT) or 3/8" (DWAMRA38FT) square drive, the sockets seamlessly attach, eliminating the need for additional socket adapters. The forged gears withstand tough applications and provide up to 10x Longer Life* while the 2-in-1 design allows users to quickly switch between standard and ultra-compact attachments.

Part of the DEWALT FLEXTORQ® Modular Right Angle System†, you can now command even more tight spaces. Available now where DEWALT products are sold.



†Compatible with DEWALT® DWAMRA14FT and DWAMRA38FT.

*DEWALT FLEXTORQ® Right Angle Compact Head Attachment has 10X LONGER LIFE vs. MILWAUKEE® 48-32-2100 on average, using DEWALT impact driver DCF887 and the compact head attachment only. MILWAUKEE® is a registered trademark of Milwaukee Electric Tool Corp., which is not approved or endorsed by this claim.

For more information, visit www.dewalt.com

CONNECT DIRECTLY TO AND SAFELY MONITOR UP TO 15KV

MODEL 15KVPSET VOLTAGE PROBES

THE MODEL 15KVPSET VOLTAGE PROBES ALLOW CONNECTING POWERSIGHT POWER ANALYZERS DIRECTLY TO 3-PHASE VOLTAGES UP TO 15 KILOVOLTS. NORMALLY, PROFESSIONALS WHO WISH TO MEASURE 12,470 VOLT LINES NEED TO LOCATE OR INSTALL A PT (POTENTIAL TRANSFORMER) IN ORDER TO MONITOR MEDIUM VOLTAGES. THE 15KVPSET ALLOWS DIRECT CONNECTION OF MEDIUM VOLTAGES TO POWERSIGHT ANALYZERS. SHOWN WITH OPTIONAL HOT STICKS, THE 15KVP HAS SHEPHERD HOOKS FOR HANGING ON BARE CABLE, TAPING OR BOLTING TO BUS BAR, OR ANY OTHER CONNECTION THAT IS NEEDED. THE 15KVPSET COMES DISASSEMBLED IN ITS OWN COMPACT CANVAS CARRYING CASE.



15 KVP Voltage Probe (Single)

15KVPSet (3 Probes, 9 Hot Sticks, Case)

BUY • RENT • TRADE IN



The World's Only Medium Voltage Direct Connection Solution for Portable Power Analysis.

Made in USA
with US & Imported Parts

Products in Stock!

Most Orders Ship in 1-2 Days!

advertiser
INDEX

This advertiser index is compiled as a courtesy to our readers. While every effort is made to provide a complete and accurate listing of companies and page numbers, the publisher is not responsible for errors. **Click the company name or page number to see their advertisement.**

Company	PG#	Company	PG#
APPLETON / EMERSON	13	PHOENIX CONTACT	5
APPLETON / EMERSON	15	POWERSIGHT / SUMMIT TECHNOLOGY, INC	31
CONDUIT REPAIR SYSTEMS	4	RANDL INDUSTRIES	21
EVLUMA	11	SOLAHD / EMERSON	17
EVLUMA	20	SOLAHD / EMERSON	23
GREAVES USA	IBC	SP PRODUCTS INC	3
ITOOLco	IFC	SP PRODUCTS INC	19
KRENZ & COMPANY	32	SP PRODUCTS INC	26, 27
MILLER SAFETY CONSULTANTS, LTD	7	SP PRODUCTS INC	BC
MOBILE DESK	1	UNDERGROUND DEVICES	29
MOBILE DESK	25		

When it comes to transformer cooling fans, Krenz-Vent is the industry recognized gold standard. Our leadership position is earned through 80+ years of R&D plus our superior engineering and customer service. You can rest easy when you specify Krenz fans.

ENGINEERED TO COOL
There is no comparison.



KRENZ & COMPANY, INC.
KRENZVENT.COM • 262.255.2310 • KRENZ@KRENZVENT.COM

BONUS FEATURE

TO VISIT AN ADVERTISER'S WEBSITE, SIMPLY CLICK THE QR CODE OR COMPANY NAME IN THEIR AD.



Electrical Products & Solutions
The Partnership Guide for Electrical Contractors

Making perfect connections has never been simpler. In fact, now it's a **SNAP!**

NEW SNAP Connectors from Greaves. A revolutionary compression connector concept that gets the job done with just a few turns of a standard wrench!

- ▶ Time-saving, easy installation
- ▶ Superior pull-out strength and conductivity
- ▶ No bulky and costly tools and dies



860-664-4505 | 800-243-1130 | www.greaves-usa.com | info@greaves-usa.com



SPPRODUCTS, INC.

Productivity and value thru ideas
FOR SAFER BETTER FASTER JOBS



We're Proud to be the Electricians' Friend for Over 50 Years!

IP5

"The Original"

Enter Any KO on Both Sides of the Box

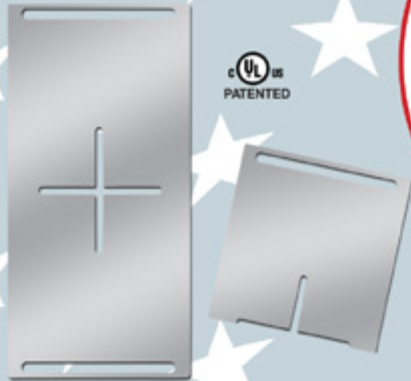

IP19/20
4-Conduit Block
PATENTED

IP21a
QwikBlock
PATENT PENDING

Use 4-Conduit Block (IP19 or IP20) with QwikBlock (IP21a)

IP6d

2-Way with Split Fingers for Horizontal or Vertical Installation

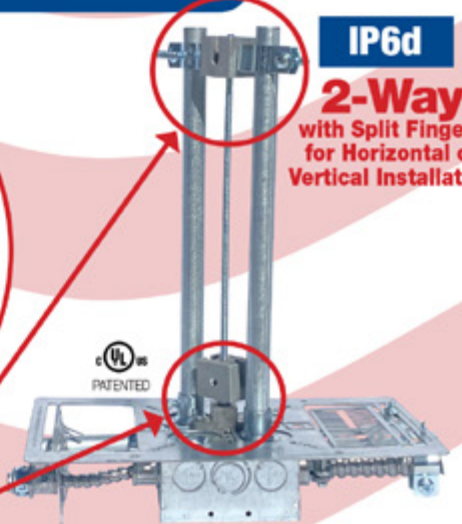

Our Family of Conduit & Box Support Plates Saves Valuable Time & Money!

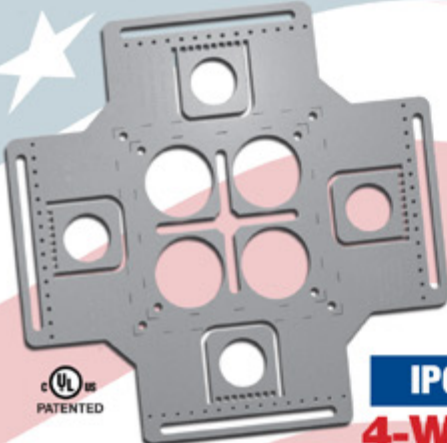

IP6

4-Way

Enter Any KO on All 4 Sides of the Box Plus 4 Large Open KOs in Center Allows Entering Back of Box

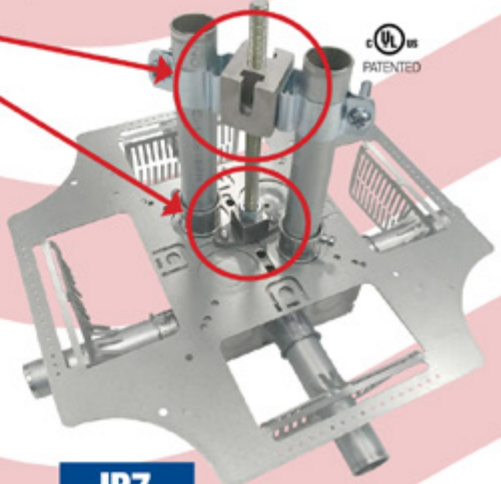

IP7

4-Way

with Split Fingers for Horizontal or Vertical Installation. Enter Any KO on All 4 Sides of the Box Plus 4 Large Open KOs in Center Allows Entering Back of Box.



IP6a

2-Way/Half

Enter Any KO on 1 or 2 Sides of the Box Plus Large Open KOs in Center Allows Entering Back of Box

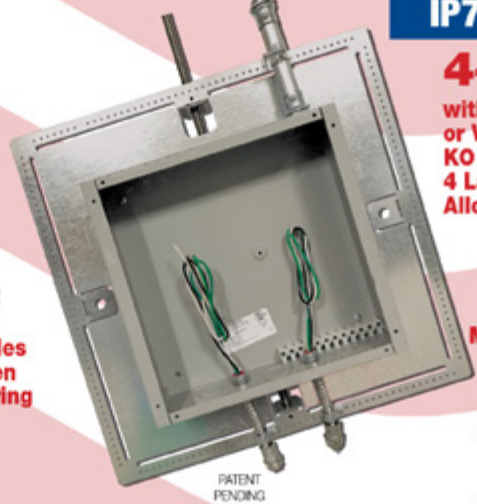

PATENT PENDING

IP8

Mount Horizontally or Vertically from One Single Support

20 x 20

Supports up to 12 x 12 J-Box

28 x 28

Supports up to 20 x 20 J-Box

MADE IN THE USA!

Plus More Being Invented for *SAFER BETTER FASTER* Jobs . . . Call With Your Ideas!

SPProducts.com **800-233-8595** info@SPProducts.com