

FEBRUARY 2023

# Electrical

## Products & Solutions™

*The Purchasing Guide for Electrical Contractors*

[www.epsmag.net](http://www.epsmag.net)



**Whole Home  
Renovation Calls  
for Whole Home  
Solutions**

# CORDLESS CANNON 6K

# iTOOLco.

WWW.ITOOLCO.COM | 865.670.3713



Speed, versatility, and performance are all yours with iTOOLco's Cordless Cannon 6K™. This portable 6,000 lb. puller is intuitively designed to handle all of your day-to-day wire pulls.

The built-in capstan switch automatically turns the puller on and off. Simply tug on the rope to start the pull and slack off the rope to shut it down. Delivers dynamic performance in remote locations or areas where power is not yet available.



# DRIVEN TO DELIVER

## THE CONSOLE X



- Clean up those cabs and get your fleet organized!

## Your Total Mobile Office Solution

*The Truck Console -X combines your Laptop Work Station, Radios, Speakers, Cables, Storage and Cup Holders. No Drill Installation Brackets Included.*

The **Truck Console -X** is the latest innovative mobile office solution to join the Mobile Desk brand family of products. This complete control, communication and convenience Utility Truck Console is becoming the new standard for fleets of all sizes. The design of the **Truck Console -X** has originated from our years of experience working directly with the lineman, supervisors, communications, and fleets of some of the most notable utility companies in America. Loaded with standard and optional features that maximize ergonomics, productivity, and fleet/telecom standards into one Mobile Office Solution.

## Screen Out™ SCREEN-DISABLER™

Blanks your screen while you drive!

Our Patented Screen Out App **Stops texting** while driving for all employees on all tablets, laptops and smart phones that run Windows, iOS or Android Operating Systems. *It's that easy!*

877-663-3375 Ext 303. [www.screenout.net](http://www.screenout.net)

Find us on:



# MOBILE DESK

MOBILE OFFICE SOLUTIONS

1-877-663-3375

[www.mobiledesk.com](http://www.mobiledesk.com)

©2018 Mobiledesk

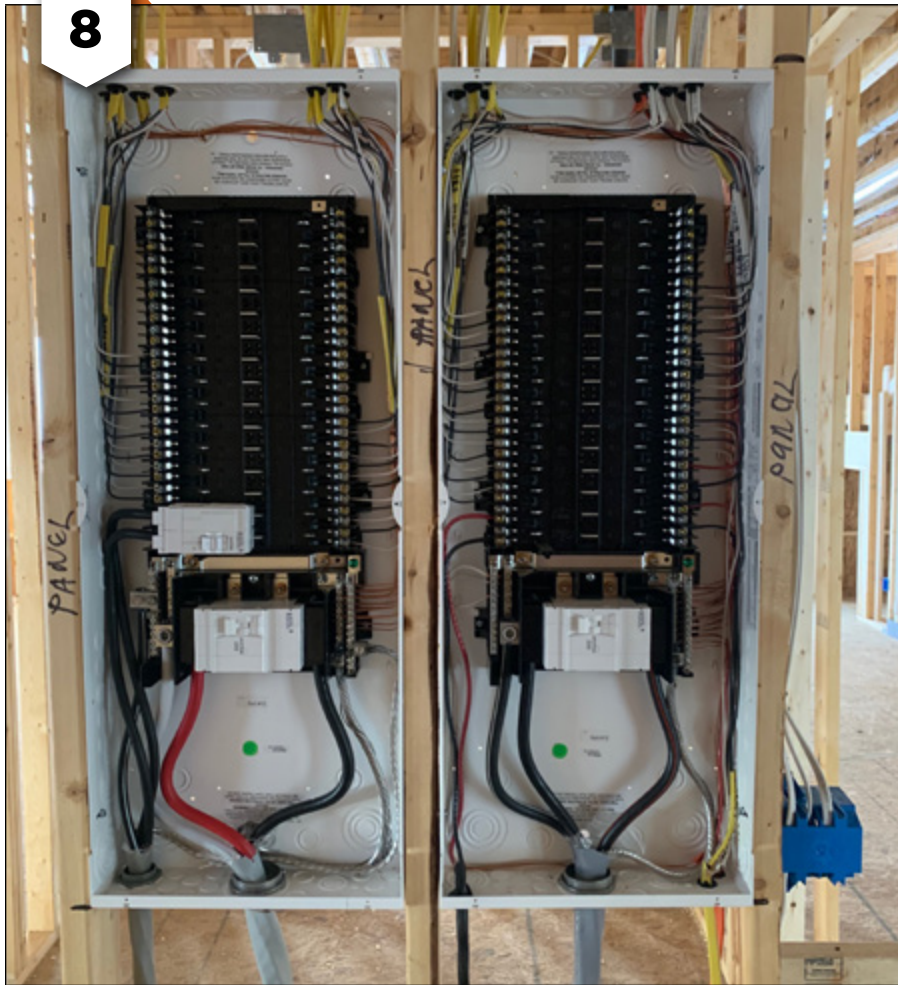

**COMPANY PROFILE**

**6 Protect Yourself**  
Miller Safety Consultants –  
*A Leader in Arc Flash Protection*

**COVER STORY**

**8 Whole Home Renovation Calls for Whole Home Solutions**  
RGN Construction, Marietta, GA

**DEPARTMENTS**

- 14** INDUSTRY NEWS
- 20** NEW PRODUCTS
- 32** AD INDEX

**ON THE COVER**

Photo courtesy of Leviton



**Electrical Products & Solutions™**  
The Purchasing Guide for Electrical Contractors www.epsmag.net

**PUBLISHER**  
Danny J. Salchert

**OFFICE MANAGER**  
Anita Salchert

**CREATIVE DIRECTOR**  
Derek Gaylard

**CIRCULATION DIRECTOR**  
Pam Fulmer



**PRESIDENT**  
Danny J. Salchert

**EXECUTIVE AND ADVERTISING OFFICES**  
2009 Eagle Ridge Drive  
Birmingham, AL 35242  
**phone:** 205.981.4541  
www.epsmag.net  
danny@epsmag.net

*Electrical Products & Solutions™* is published twelve times a year on a monthly basis by ABD Communications, Inc., 3591 Cahaba Beach Road, Birmingham, Alabama, 35242, USA. *Electrical Products & Solutions™* is distributed free to qualified subscribers. Non-qualified subscription rates are \$57.00 per year in the U.S. and Canada and \$84.00 per year for foreign subscribers (surface mail). U.S. Postage paid at Birmingham, Alabama and additional mailing offices. *Electrical Products & Solutions™* is distributed to qualified readers in the electrical contracting industry. Publisher is not liable for all content (including editorial and illustrations provided by advertisers) of advertisements published and does not accept responsibility for any claims made against the publisher. It is the advertiser's or agency's responsibility to obtain appropriate releases on any item or individuals pictured in an advertisement. Reproduction of this magazine in whole or in part is prohibited without prior written permission from the publisher.

**POSTMASTER:** Send address changes to ABD Communications, Inc., P.O. Box 382885 Birmingham, Alabama 35238-2885

**FOLLOW US ON**



**SPPRODUCTS, INC.**  
*Productivity and value thru ideas*  
**FOR SAFER BETTER FASTER JOBS**



*We're Proud to be the Electricians' Friend for Over 50 Years!*

**Qwik Duct**  
**Safer Better Faster**

**HDPE CUSTOM TEMPLATES**  
*In Any Configuration Required*

**Save on Installation!**



**IP1**  
cULus  
Patent Pending

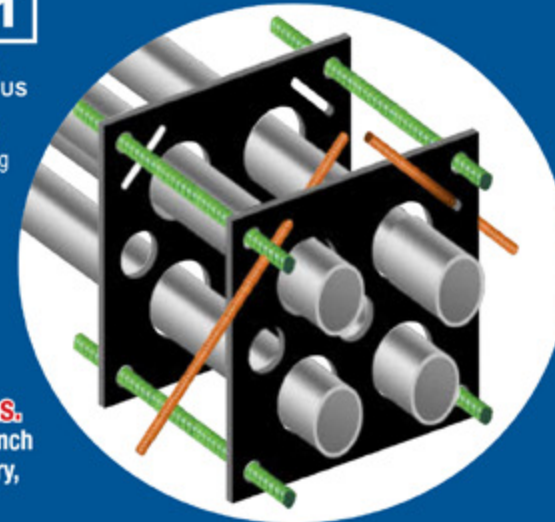

**IP3b**  
Patent Pending



**PVC Offset**  
Sizes 1/2" thru 6"  
Meets Flexible Mandrel Test Requirements

**Bore Spacers IP2**  
Sizes 1/2" thru 6"  
Roll assembled conduit into caissons and under obstructions



Assemble Conduit Above Trench -  
**No Workers Below - Prevents Injuries and Deaths.**  
Also Allows Digging a Narrower Trench for Less: Excavation, Concrete, Slurry, Backfill & Shoring.

**IP13A-F**

**Conduit Transition Couplings**

**PVC Schedule 40 & 80 Transitions in Less Than 5 Minutes**

**IP15 End Bell Adapter** Schedule 40/80 PVC PATENT PENDING

**IP14a 1 Piece Reaming Bit** 1/2" thru 6" Schedule 40/80 PATENT PENDING

**Save Cost on the Rigid Nipple, Tape & Labor Use for Entire Job - Not Just for Repair**

*Plus More Being Invented for SAFER BETTER FASTER Jobs... Call With Your Ideas!*



SPProducts.com 800-233-8595 info@SPProducts.com

# REPAIR CONDUIT IN A SNAP!

No Tape • No Plastic Straps • No Metallic Straps

## NO KIDDING!

*Designed especially for power, communications and fiber optics.*



**STEP 1**  
Remove damaged conduit

**STEP 2**  
Cut split duct conduit to fit

**STEP 3**  
Snap in place

**STEP 4**  
Attach adapters

**STEP 5**  
Finish job in record time

*“The World Leader In Split Conduit Products”*



**Conduit Repair Systems, Inc.**  
The World Leader In Split Conduit Products



800.670.1804 • 435.673.8724 fax • crs@conduitrepair.com • www.conduitrepair.com

THE  
**TOOL fox**

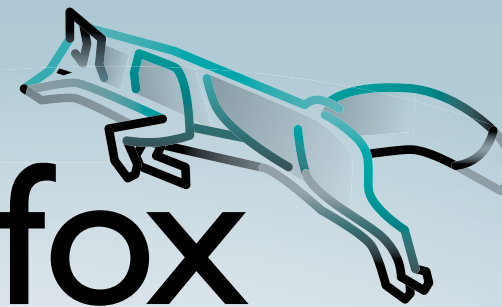

## TOOLS you can TRUST

Partner with the TOOL fox to take advantage of these benefits:

- Robust, durable, and ergonomic industrial wire-processing hand tools
- Cut, strip, and crimp with consistent high-caliber results
- UL Listed when used with Phoenix Contact's quality ferrules
- Backed by a dedicated sales team and technical service
- Covered by a limited lifetime warranty



For more information and videos, please visit  
[www.phoenixcontact.com/us-TOOLfox](http://www.phoenixcontact.com/us-TOOLfox).



© PHOENIX CONTACT 2023



# Protect Yourself

## Miller Safety Consultants — A Leader in Arc Flash Protection

Vince Miller started Miller Safety Consultants, a veteran owned business in 1999. The goal of the business was to provide cost effective safety consulting, employee training such as: confined space entry, fall protection, electrical safety and provide sales of electrical shock and flash protective equipment and fall protection equipment to businesses in the Washington DC area.

Reliance Industries provided fall protection products and much of the sales and training was on behalf of the supplier. In 2000, the owner decided to retire from his business, and Vince decided to discontinue the fall protection line of his business and concentrate more in the electrical training and products.

Vince had been a distributor for Certified Insulated Products (CIP), a manufacturer of electrical insulated tools and electrical arc flash clothing manufactured by Otex in Rochester, New York. As a distributor, Vince provided sales through his internet website and much through relationships with electrical contractors. His training was a classroom environment and was provided directly to customers but he also taught as a sub-contractor for other safety consulting companies and the

Chesapeake Safety Council in Baltimore, Maryland. In 2005, Vince partnered with Vivid Learning Systems in Cascades, Washington to provide on-line training in safe work practices.

Training in electrical safe work practices is still provided locally in the Washington DC area and as a partner with an electrical engineering firm and online. The training is based on the Occupational Health and Safety Administration (OSHA) standards and the National Fire Protection Association (NFPA) 70E standard.

Miller Safety Consultants is now a distributor for Cementex USA, Burlington, New Jersey, for insulated tools and equipment and clothing from OTEX Protective, Rochester, New York.

The majority of his sales of products

are from the web-based store. Cementex is nationally known for their quality equipment. Otex Protective is becoming more known for their quality clothing. For years, they have manufactured their products under other provider labels. Vince chose to not create his clothing line, but to sell the manufacturer product.

Vince has worked with many electrical company employees to fine-tune the clothing to be more comfortable for the user. Working closely with the manufacturer, they have made slight changes in how the cloth pattern was modified to meet final production. An example is the lightweight 40 Calorie vented hood offered by Otex.

The material is of the latest technology. The vented assembly is constructed for balance on the back of the hardhat and the airflow is 27 CFM to prevent fogging of the face shield and provide cooling to the worker. It took over a year to develop the product with the user prior to having the hood "flash tested". This product is now standard issue with many electrical contractors.

Being a small business and having quality providers has resulted in satisfied customers for Miller Safety Consultants. Being a direct supplier for OTEX Protective, another small business means customized customer needs can be met. □

For more information, visit  
Miller Safety Consultants at:  
[www.electricalsafety.com](http://www.electricalsafety.com), email  
Vince at: [sales@millersafetyltd.com](mailto:sales@millersafetyltd.com).

**AUTHORIZED**  
**Cementex**  
**The Safety Tool Specialists**  
**DISTRIBUTOR**

Give Vince a call at  
**(703) 367-0404**



Deluxe Maintenance Tool Kit



Class O Glove Kit

# Protect yourself from "Arc Flash"

**ARC FLASH LIFT-FRONT HOOD WITH V<sup>12</sup> HIGH-VOLUME VENTILATOR**  
Compact. Powerful. Reliable

Our V<sup>12</sup> High-Volume Ventilator boasts an unexpectedly quiet, high output (35+ CFM) turbine fan to cool and circulate the ambient air within the hood. Fully protected beneath it's durable ABS shell and added fabric layering, the V<sup>12</sup> High-Volume Ventilator isn't just compliant, it's superior.



**40 CAL/CM2 ULTRALIGHT CLOTHING BY OTEX**

Our new dual-layer Ultralight clothing takes advantage of DuPont's® dedication to scientific advancement and Westex's® industry leading dependability. Weighing in 37% lighter than traditional HRC4 PPE, our Ultralight Clothing is the most innovative contender in the lightweight arena.

**HYBRID LAYERING**

Combined Fabric Weight: 14 oz

Outer Layer: DuPont® Protera  
Color: Navy

Inner Layer: Westex Ultrasoft  
Color: Safety Orange



CALL US TODAY  
**(703) 367-0404**

OR VISIT OUR ONLINE ELECTRICAL SAFETY EQUIPMENT STORE  
[www.electricalsafety.com](http://www.electricalsafety.com)

# Whole Home Renovation Calls for Whole Home Solutions

**RICARDO GIRALDO, OWNER OF RGN CONSTRUCTION, MARIETTA, GA,** took on the challenge of completely rebuilding a large home in nearby Smyrna, GA. The plan was to take the structure from a new foundation to a showcase home that would stand out among the beautiful properties in the area. The complete rebuild would have two floors, including a full in-law suite, and feature the latest building materials and technology with a modern electrical system.

The goal for this home, as with all RGN Construction homes, is to build high-end, quality homes that appeal to the younger buyers who value advanced home technology. Giraldo noted, “The

market seeks a new look and updated technology. It’s all about competition because demand is very high.”

After reviewing industry competitors and customer needs, Giraldo’s goal was





to deliver aesthetically pleasing, market-leading technology that intersects traditional and modern home design to provide comfort, safety, and energy conservation.

While sourcing the materials and technology for the project, Giraldo spoke with a subdivision home building associate who recommended Leviton products. “We are really pleased with Leviton,” said Giraldo. “This is our first time using Leviton, but there wasn’t a learning curve. Timing was crucial,

so the products had to be available, installed without any callbacks, and be manufactured by a trusted brand. The fact that many Leviton core products are manufactured at Leviton plants in the United States is an added advantage for our company and our customers.”

### Smart from the Start

To power the home, the team installed three Leviton Load Centers with Smart Circuit Breakers, and a sub-panel. Giraldo noted how easy

the Load Centers were to install, particularly because he was working with bottom fed feeders. He also noted the convenience of only having to use one tool to terminate the wires, and that termination can be done without the circuit breakers present in the panel, making the job faster, easier, and helping to prevent theft. Leviton Decora Smart® products were used for lighting control throughout the home, and Giraldo pointed out how the products make it easy for electricians to install and for homeowners to use. “Smart products often require explanations for buyers, but once they understand the technology, it’s a great selling point!” said Giraldo. “People like the idea that they can manage their electrical system from anywhere. Leviton’s smart products were easy to explain, and the buyer was quickly able to learn and use the systems.”

While Giraldo credits Leviton’s

**“The market seeks a new look and updated technology. It’s all about competition because demand is super high.”**

— Ricardo Giraldo

# AMERICAN MADE. RONK SOLID.

Since the 1950’s, RONK has been striving to give you the best possible top-quality products and services. We pride ourselves on all our products being made in America and manufactured at our own facility in Central Illinois.

Offering products such as robust transfer switches, phase converters, stray voltage isolators, and meter socket circuit breakers, RONK Electrical has the right product for your power system needs.

Serving industries such as agriculture, oil and gas, utilities/electrical co-ops, waste & wastewater, we feature lead times shorter than our competitors, and the promise that our products will last for decades. Using naturally corrosive resistant aluminum enclosures for our products, RONK knows that your company deserves the best.

## SERIES 4+ MANUAL TRANSFER SWITCH



**RONK**

### RONK ELECTRICAL

106 E State Street, PO Box 160  
Nokomis, IL 62075-0160

Sales: 1-800-221-7665

Service: 1-217-563-8333

[www.ronkelectrical.com](http://www.ronkelectrical.com)





Decora Smart and Smart Load Center features for making this \$1.4 million dollar house stand out in a competitive market, additional Leviton devices are featured in the home – including GFCIs, USB Charger Devices, and lighting controls – bringing industry-leading safety and convenience. Using best-in-class products and solutions allowed him to quickly close the sale of this property in record time. □

**The fact that many Leviton core products are manufactured at Leviton plants in the United States is an added advantage to Mr. Giraldo and to his customers.**



## Extend Luminaire Life While Reducing Energy Consumption

The Appleton™ Mercmaster™ Connect LED by Emerson is designed to illuminate hazardous and harsh industrial locations with integrated motion and illuminance sensors. Paired with Emerson’s Plantweb Insight Connected Lighting Application, operators have access to lighting usage data and sustainability analytics.

The Mercmaster Connect LED provides facility managers with continuous monitoring of their LED lighting with real-time insights gained into sustainability goals, diagnostics and lumen levels from any remote location at dramatically lower costs as compared to wired alternatives, with faster installation time and minimal disruption to plant operations.

Learn more at: [masteringled.com](http://masteringled.com)



Appleton™ Mercmaster™ Connect LED

**APPLETON™**

The Emerson logo is a trademark and a service mark of Emerson Electric Co. © 2021 Emerson Electric Co.

**EMERSON**

**CONSIDER IT SOLVED™**



## Detroit, Southeastern Michigan Welcomes New Sales Manager, Bill Prevo



Recently, WAGO named Bill Prevo their new Regional Sales Manager for Southeastern Michigan, including Detroit and the surrounding area. For the past decade, Bill has had success as an Automation Field Sales Engineer. He has also worked in electrical services in the water and wastewater industry.

Aside from the product quality, the biggest draw for him coming to WAGO was the positive communication, family-friendly atmosphere and how long some of their employees have been with the company. "I am so excited to be part of the WAGO family," Prevo says. "The employee retention here is amazing and was a major reason for wanting to be a part of the team."

Welcome to WAGO Bill!

## WAGO Tabs Diane Pena to lead Electrical Contracting and Wholesale Sales



Diane Pena has recently been hired as WAGO's new Electrical Contractor and Wholesale Sales Manager. Originally from Chicago, Diane is based just outside of Atlanta, GA where she has worked in the lighting industry for over the past 15 years.

She lists her marketing background as a strength and plans to use the challenge of switching industries as motivation in her new role. "By bringing my knowledge of the lighting industry as well as long term relationships with reps and customers, I hope to impact WAGO in a positive way," Pena says.

Good luck Diane and welcome to WAGO! □

### ABOUT WAGO

Innovation is at the heart of everything we do at WAGO. From our pioneering CAGE CLAMP® spring pressure connection technology to our extensive range of Interconnect, Interface and Automation solutions, such as the fieldbus independent WAGO-I/O-SYSTEM, our customers count on the unconditional performance and reliability of our products to ensure the safe, efficient operation of their systems every time. For additional information, visit [www.wago.us](http://www.wago.us). Contact WAGO at 1-800-DIN-RAIL or [info.us@wago.com](mailto:info.us@wago.com).



## Lighting Your Way at Greater Heights

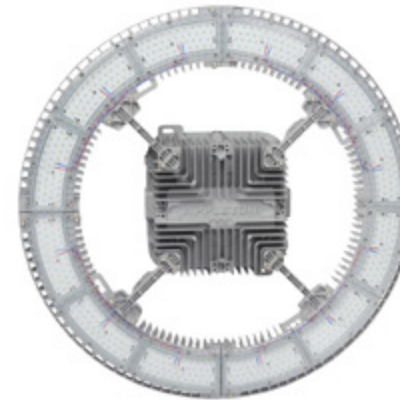

Appleton™ IHC LED Luminaire

The Appleton™ IHC LED Luminaire by Emerson is the ideal solution to deliver light from mounting heights of 50 to over 100 feet. With outputs up to 90,000 lumens, an IP66 marine and wet location rating, and an ambient temperature range of -40 °C (-40 °F) to 75 °C (167 °F), the IHC was designed to meet the demands of your harsh industrial environment and lighting requirements.

Learn more at: [masteringled.com](http://masteringled.com)

APPLETON™

The Appleton logo is a trademark and a service mark of Emerson Electric Co. © 2021 Emerson Electric Co.



CONSIDER IT SOLVED™

# Leviton Expands Camargo Manufacturing Facility in Chihuahua, Mexico

Breaks ground on 80,000 square foot production facility to support growing customer needs

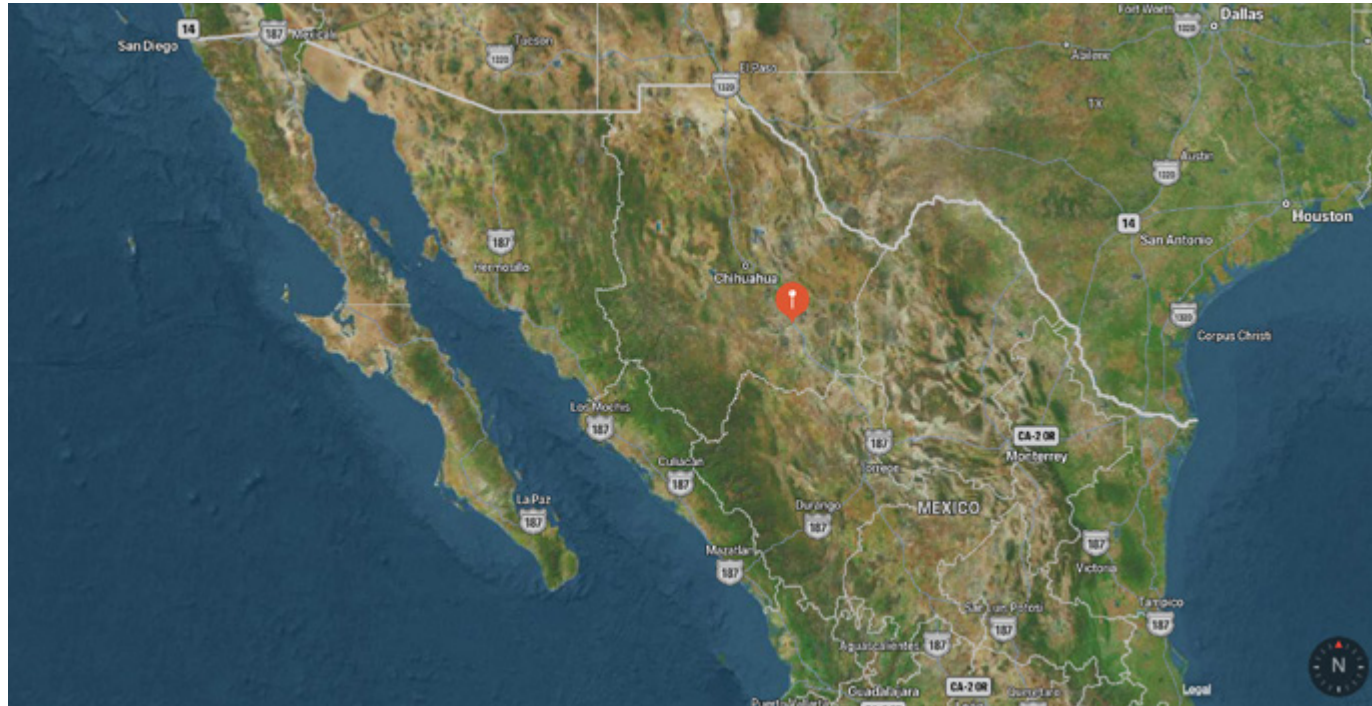

Leviton, a leading provider of electrical wiring devices, networking and lighting, today announced the expansion of its manufacturing facility in Camargo, Mexico.

The over 80,000 square foot facility will house several new production lines and a distribution center for more efficient operations, as well as areas that benefit employees such as dedicated offices, a cafeteria and recreational center. The new facility will add 300 positions to the Leviton workforce in the region.

“We’ve been manufacturing products in Camargo for over 25 years and are extremely excited to be expanding our footprint yet again in this region,” said Michael Mattei, executive vice president & general manager, Leviton Commercial & Industrial. “As customer needs and dynamics shift, we’re staying ahead in terms of how we meet demand and develop new products. In this new space, we’re adding technology and manufacturing capabilities that will allow us to even better serve our customers.”

The facility will manufacture products for all four Leviton business units and serve customers across the world. Incorporating automation and new technology in the facility will also improve Leviton’s ability to meet capacity demands, improve lead times and bring new products to market in a faster and more sustainable manner.

Focusing on reducing its overall environmental impact and empowering and enabling customers to be more sustainable, Leviton’s goal to achieve company-wide Carbon Neutrality by 2030 (CN2030) will be reflected in the construction and the expansion of the Camargo facility.

“It was important to incorporate our CN2030 efforts in building this facility,” said Jaime Estrada, vice president, Chihuahua Operations. “As Leviton strives for carbon neutrality by 2030, the expanded Camargo facility will adhere to Green Building Initiative standards.”

Leviton expects to complete construction later this year. □

## ABOUT LEVITON COMMERCIAL AND INDUSTRIAL

Leviton’s comprehensive line of commercial and industrial-grade electrical wiring devices provide builders, contractors and specifiers with solutions engineered to withstand the most rigorous commercial environments and harshest industrial applications. Leviton manufactures everything from commercial, industrial and hospital grade wiring devices, to surge protective devices, electric vehicle supply equipment, temporary power solutions, heavy duty motor starter switches, IEC and NEMA watertight rated devices and more. Learn more at [www.leviton.com/commercial](http://www.leviton.com/commercial).



## Versatile Mounting for Extreme Environments

The SolaHD™ SCP-X Series Standalone IP67 Power Supplies by Emerson can be mounted almost anywhere on a machine, conveyor, or wall. With no enclosure required they offer safety against arc flash hazards.

Quick-connect cables ensure the IP67 rating and eliminate costly wiring. Available from 100 Watts to 240 Watts, the SCP-X Power Supplies meet the diverse needs of automotive manufacturing, conveyor systems, and equipment where 24 Vdc power is required for geographically dispersed devices.

Learn More at: [www.solahd.com](http://www.solahd.com)



SolaHD™ SCP-X Series Standalone IP67 Power Supplies

SOLAHD™

The Emerson logo is a trademark and a service mark of Emerson Electric Co. © 2021 Emerson Electric Co.



CONSIDER IT SOLVED™

# Robroy Industries® names Clinton Gehrman as Raceway Division President

Robroy Industries Raceway Division recently announced Clinton Gehrman as the new division President. Clinton previously spent six-and-a-half years as President at Instrument Transformer Equipment Corporation in Monroe, North Carolina. Clinton has worked in various management and leadership positions within electrical equipment companies such as Eaton, Solomon Corporation, and Cooper Power Systems resulting in over 25 years of manufacturing excellence. He holds a bachelor's degree in Mechanical Engineering from Mississippi State University and a master's degree in Business Administration from Stephen F. Austin State University.

"I'm glad to have found someone as knowledgeable and humble as Clinton to join our growing team," says Steve Voelzke, President of Electrical Products at Robroy Industries. "We are excited for him to bring his track record of manufacturing excellence and constant improvement to our organization."

In his new role as Raceway Division President, Clinton will oversee the day-to-day business of the Plasti-Bond, Perma-Cote, Rocket Rack, Robroy Stainless and ECN/Korns families of raceway products, as well as be responsible for management of division objectives, organizational development, and sustainable growth strategies.



#### ABOUT ROBROY INDUSTRIES RACEWAY DIVISION:

Robroy Industries is a family-owned manufacturer of electrical products with a history of leadership in corrosion resistant electrical products that spans over 118 years. The Raceway Division manufactures complete lines of PVC-coated and stainless-steel conduit, fittings, and accessories, as well as pre-engineered, factory-fabricated sanitary support systems. Manufactured in the U.S.A., ISO 9001-certified, the PVC-coated lines comply with all standards mandated by UL 6, NEMA RN-1, ANSI C80.1, UL 1203 and ETL PVC-001; the stainless-steel line complies with all standards mandated by UL 6A, ANSI C80.5, UL 514B and NSF/ANSI/3-A 14159-1. For more information, visit [www.robroy.com](http://www.robroy.com).



MADE IN USA

# SPPRODUCTS, INC.

Productivity and value thru ideas  
**FOR SAFER BETTER FASTER JOBS**

*We're Proud to be the Electricians' Friend for Over 50 Years!*

**IP15a**  
**Chamfer Bit**  
for PVC SCH 40/80

PATENT PENDING

Smooth Beveled Edge after Chamfering

**IP27b**  
**Electro Post EP-10**  
Box Support Bracket

Mounts on all standard stud widths of 2-1/2", 3-5/8" or 6"

PATENT PENDING

**IP15b**  
**Chamfer Bit**  
for Aluminum EMT

PATENT PENDING

Smooth Beveled Edge after Chamfering

**NEW PRODUCTS**

**IP7**

**4-WAY CONDUIT & BOX SUPPORT PLATE**  
with Split Fingers for Horizontal or Vertical Installation

Use 4-Conduit Block (IP19 or IP20) with QwikBlock (IP21a)

PATENTED

**IP21a**  
QwikBlock

PATENT PENDING

**PVC Running Thread SCH 40/80**  
Up to 30" Long

PATENT PENDING

**IP3d**

**NEW Transition Fittings**  
Saves a Great Deal of Time Repairing Conduit  
The Inside Diameter Remains the Same  
Allows for Trouble Free Wire and Cable Pulls

**IP13p**  
3/4" MC Cable to PVC

**IP13k**  
Inside PVC to Inside PVC

**IP13q**  
PVC Reducer

PATENT PENDING

**Male Threaded PVC Offset**

**IP3c**

1/2" thru 3" Offset for Conduit Sizes 1/2" thru 6"

PATENT PENDING

Plus More Being Invented for SAFER BETTER FASTER Jobs . . . Call With Your Ideas!

SPProducts.com 800-233-8595 info@SPProducts.com

**Prevent Water Damage to Electrical Systems with O-Z/Gedney Weatherproof Boxes, Covers & Lampholders**

O-Z/Gedney weatherproof single- and two-gang boxes, covers, and lampholders prevent entry of damaging dirt, dust, and moisture into electrical systems. Constructed of durable PVC or polycarbonate, these rugged products are engineered for highly corrosive industrial areas, or wet outdoor locations, such as parking lots, marinas, beaches, docks, and pools. Continuous box and cover compression ensures complete sealing at the gasket interface.

By using these products, electricians will achieve needed protection when installing branch circuit wiring, switches, receptacles, GFCIs, or lighting in wet locations. In addition to sealing out moisture, the boxes, covers, and lampholders are resistant to impact, mold, and distortion from extremely hot or cold temperatures. Electricians will appreciate the smooth, accurately tapped hubs that prevent wire abrasion, and how the formed-in-place mounting lugs improve installation efficiency. Also, locking swivel knuckles on the lampholders enable positive lamp positioning and accurate directional aiming.

Weatherproof boxes are available as gray or white 1-gang, 2-gang, or round boxes with matching covers including lockable models. Lampholders are conveniently supplied with locknuts, porcelain sockets, and internal gaskets. Clear UL and volumetric markings are cast into each box to facilitate electrical inspections. O-Z/Gedney weatherproof boxes, covers, and lampholders are cULus Listed and UL and CSA Certified.



For more information, visit [www.o-zgedney.com](http://www.o-zgedney.com)



**Vertiv Introduces New Lithium-Ion UPS to Support Retail Point-of-Sale, Workstations, and Other Small Compute Applications in North America**

*Vertiv™ Liebert® Power-UPS Lithium designed to provide reliable, economical and long-lasting power protection for critical smaller spaces*

Vertiv, a global provider of critical digital infrastructure and continuity solutions, recently announced the release of its Vertiv™ Liebert® Power-UPS Lithium uninterruptible power supply (UPS), designed to protect retail point-of-sale (POS) equipment, computers, workstations, wireless networks and routers, surveillance systems and other electronics. The Liebert® Power-UPS Lithium UPS system will be available in Q2 2023 in North America.

The ENERGY STAR certified Liebert Power-UPS Lithium is an efficient, compact and lightweight 400VA/240W 120V UPS system that utilizes lithium-ion battery technology with an 8 to 10 year expected battery life, significantly reducing on-going battery replacements, and providing users with lower cost of ownership. When compared to traditional valve-regulated-lead-acid (VRLA) batteries, lithium-ion batteries have greater power density, last up to three times longer, recharge faster and can endure up to 10 times more discharge cycles. Its flexible design, and a weight of less than four pounds, allows the UPS to be installed in a variety of configurations, making it a convenient solution for environments where space is limited.

“The evolution of remote work, education and small business operations has us relying more on digital equipment and technology to support the essential functions of daily life, which only increases the need to protect these devices from power disruptions,” said Ramesh Menon, vice president, single phase UPS and ITS at Vertiv. “The Liebert Power-UPS Lithium is designed to provide economical and long-lasting power protection that helps maintain uptime and reduce the chance of data corruption by keeping important electronics, including critical retail point-of-sale systems, connected and protected.”

A highly reliable system, the UPS is designed to endure operating temperatures of up to 104 degrees Fahrenheit (40 degrees Celsius) and is ideal for environments with limited airflow and high temperatures. Other features include reliable alarm management, which allows users to quickly identify the problem and to silence the alarm when on battery, and a standard five-year warranty, for added peace of mind that user devices will remain protected and connected.

For more information, visit [Vertiv.com](http://Vertiv.com)

First there was 4 square...  
and now the **REVOLUTIONARY 5 Square® Box!!**

You've struggled with 4 Square boxes for years - you know how small, cramped and time consuming they are. Finally, there is a solution that allows you the space you have always needed.

The **5 Square®** Boxes (5" x 5" x 2-7/8") provide up to 88 in<sup>3</sup> of interior volume which more than doubles that of most existing boxes on the market.

Create a robust and unrivaled infrastructure for the life of your facility with the **5 Square®** Products!



**Fire Signal**



- TWICE THE VOLUME AS MOST BOXES
- SAVE LABOR...INCREASE PROFITS
- ELIMINATES TROUBLESHOOTING TIME AND COST
- FULLY UPGRADEABLE SYSTEM
- SPECIFIED BY ENGINEERING FIRMS, HOSPITALS, UNIVERSITIES & GOVERNMENT AGENCIES
- AVAILABLE IN ZINC OR RED

**Telecommunications**



- INTEGRAL CABLE MANAGEMENT
- SAVE LABOR...INCREASE PROFITS
- FACILITATES MIN. BEND RADIUS REQUIREMENTS
- SUPPORTS CURRENT AND EVOLVING SYSTEMS
- SUPPORTS PoE PLUS
- SPECIFIED BY ENGINEERING FIRMS, HOSPITALS, UNIVERSITIES & GOVERNMENT AGENCIES

**Milwaukee Tool's Newest REDLITHIUM™ USB Flashlight Provides Faster Beam Adjustments**

Milwaukee® continues to expand its REDLITHIUM™ USB Flashlight lineup, delivering the most advanced LED technology and optical designs for a more efficient workday. The REDLITHIUM™ USB 2,000 Lumen Slide Focus Flashlight Light provides users with a premium lighting solution for inspection work, allowing users to maximize productivity while adjusting to the needs of the job.

Providing faster beam control, the REDLITHIUM™ USB 2,000 Lumen Flashlight features a slide-focusing design, allowing users to quickly and easily slide the head of the light from flood mode into spot mode. The USB-C rechargeable flashlight has a multi-functional rear power button that offers battery indication and mode selection. Featuring four output modes: low (100 lumens), medium (800 lumens), high (1,300 lumens), and a new Milwaukee Boost Mode (2,000 lumens), users can maximize the flashlight's output and run-time. With a beam distance of 200M (656 feet), this feature allows users to identify problems during an inspection while being further away.

Built to survive the jobsite, the flashlight is dustproof and water resistant with an IP66 rating and can withstand a 13-foot drops. A removable metal pocket clip allows users to adapt to the needs of their jobsite. The REDLITHIUM™ USB 2,000 Lumen Slide Focus Flashlight is powered by the REDLITHIUM™ USB 3.0AH Battery, providing all-day run-time, more recharges, and 3x faster charge time.

Focused on the user and investing in game-changing technology, Milwaukee Tool continues to design and develop jobsite lighting solutions with the ability to adapt, perform, and survive the demands of professional use.

\* REDLITHIUM™ USB gives users rechargeable convenience and performance where maintaining a compact size is critical and eliminates the downtime associated with other rechargeable solutions due to slow charge speed or integrated batteries. Capable of being charged either on the product or a separate charger and with a 3X faster charge time, users can get back to work more quickly. Plus, with over 2,000 recharges, REDLITHIUM™ USB eliminates the dependency on disposable batteries in situations of extended use.

\*\* TRUEVIEW™ Technology utilizes the most advanced LED technology and optical designs to deliver a consistent beam, optimized color temperature, and true representation of colors and detail leading to a more productive work area.



**For more information, visit**  
[milwaukeetool.com](http://milwaukeetool.com)



**Cementex Highlights the Automotive Electric Service Tool Kit**

*Customizable insulated tool kit ideal for service on hybrid and electric vehicles*

Cementex, the safety tool specialists, highlights the Cementex Automotive Electric Service Tool Kit (ITS-12B-AES), a great base of insulated tools for use with hybrid and electric vehicles (EVs) as well as troubleshooting and repair to EV charging stations.

Stored in a standard tool box, this tool kit includes Cementex double-insulated Diagonal Cutting, Needle Nose, Slip Joint, Crimping, and Water Pump Pliers, as well as a variety of double-insulated Cushion Grip screwdrivers. Cementex double-insulated tools are Made in the U.S.A. Cementex tools are tested to 10,000 VAC and rated for 1,000 VAC/1,500 VDC when working on energized parts, and are marked with the (double-triangle) international safety symbol.

As with all Cementex tool kits, these combinations of tools can be customized to fit an individual customer's needs. The Arc flash PPE required while conducting maintenance and repair on energized electric vehicles is available from Cementex as well. This includes insulating rubber gloves, aprons, Arc Flash protective clothing, and face shields.

**For more information, visit**  
[www.cementexusa.com](http://www.cementexusa.com)



**Compact and Easy to Install DC UPS for Harsh Industrial Locations**

The SolahD™ SDU DC - B Series DIN Rail UPS by Emerson are perfect for mitigating power quality issues, minimizing loss of data and downtime.



SolahD™ SDU DC - B Series DIN Rail UPS

The SDU DC - B UPS combines an industry leading compact design, wide operation temperature range -15 °C to +50 °C (+5 °F to +122 °F), enhanced communication and unique installation options to solve common application problems.

Learn more at: [www.solahd.com](http://www.solahd.com)

**SOLAHD™**

The Emerson logo is a trademark and a service mark of Emerson Electric Co. © 2021 Emerson Electric Co.



**CONSIDER IT SOLVED™**

**Channellock, Inc. Releases New 10" CODE BLUE® WIDEAZZ® Adjustable Wrench**

Channellock, Inc. expands its line of adjustable wrenches to meet the evolving needs of trade professionals.

Inspired by the ever-changing needs of America's hard-working trades professionals, Channellock, Inc. is proud to release its new CHANNELLOCK® 10WCB 10" CODE BLUE® WIDEAZZ® Adjustable Wrench.

"As the skilled trade industry continues to evolve, so should its tools," said Ryan DeArment, Vice President of Sales and Marketing at Channellock, Inc. "We introduced our new 10WCB after hearing feedback from skilled tradespeople who were asking for a longer, wider WIDEAZZ® Adjustable Wrench."

**Key Features:**

- Extra-wide, two-inch jaw capacity (up to 72% wider than a standard 10" wrench) to support larger nuts and bolts
- Longer, non-protruding jaws for greater access in tight spaces
- Minimal head width for hard-to-reach applications
- Forged from rugged chrome vanadium steel for maximum strength
- Slim and comfortable tapered-handle design
- Precise four-thread knurl for accurate adjustments
- CODE BLUE® comfort grips to reduce hand fatigue



"Innovation and adaptation have always been at the core of our company's success," said Channellock, Inc. COO and President, Jon DeArment. "Our willingness to modify our existing tools and create new ones is what has kept us in business for over 136 years and will sustain us for years to come. We want hard-working people everywhere to continue to reach for CHANNELLOCK® tools when they need to get the job done right."

Like the 6WCB and 8WCB, the new 10WCB WIDEAZZ® Adjustable Wrench is made in Spain.

**For more information, visit**  
[www.channellock.com](http://www.channellock.com)

**Luminus Releases SBT-10X UV-A LED with up to 75% Increase in Power Density**

Luminus Devices has announced the release of the SBT-10X-UV LED series, an innovative surface mount device (SMD) that utilizes Luminus' latest Gen5 die architecture. Delivering up to 75% higher output than Luminus' Gen4 die, the Gen5 technology achieves an industry leading flux of up to 5W from a single 1 mm<sup>2</sup> class chip. As such, it improves end-system performance for the most demanding curing applications including 3D printing, curing and maskless lithography, where maximum flux density directly translates to faster curing and higher productivity.

The Gen5 technology integrates know-how in very high intensity chip structures that Luminus has developed and improved for over 15 years. This technology achieves excellent reliability at drive conditions often 2x what the competition supports. It is available in 365nm, 385nm, 395nm, 405nm and 415nm wavelengths and comes in a compact 3.5 mm x 3.5 mm surface mount cavity package with a flat borosilicate cover helping maximize optical coupling efficiency into the end system.

David Nowak, Senior Marketing Manager, comments, "The SBT-10X brings our Gen5 technology in its most compact form factor which will help accelerate adoption in a wide range of industrial systems that are starved for UV-A curing

performance. We are especially excited to enable more compact, affordable high-resolution 3D printers that will help accelerate the adoption of the technology in prosumer segments thanks to affordable and compact printers that do not sacrifice quality."

**For more information, visit**  
<http://www.luminus.com>

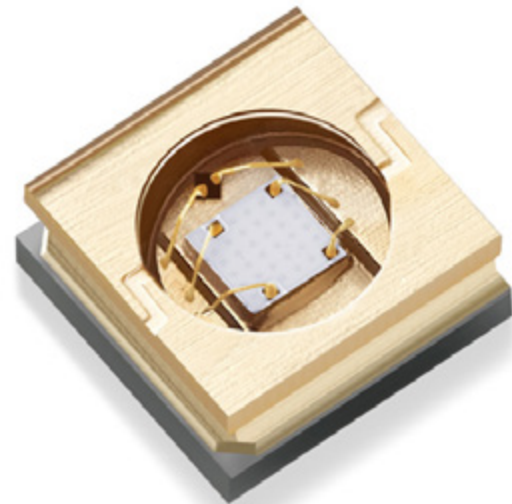

**Affordable test equipment for 2023**



**Spittfire** - Buried Low Voltage Cable Fault Locator

- ◆ Accurate
- ◆ Easy to use
- ◆ High energy output
- ◆ Proven reliability
- ◆ Compact design
- ◆ Lightweight

**Wayfind'r** - Impulse cable tracer

- ◆ Accurate
- ◆ Easy to use
- ◆ Connects directly to energized cables
- ◆ Distinct signal for easy tracing
- ◆ Traces direct buried and cables in conduit
- ◆ Rugged, compact design

**Impulse Phaser** - Cable / phase system

- ◆ Accurately identifies cables in trenches, vaults, conduits and enclosures
- ◆ Accurately identifies phases in multi-conductor cables
- ◆ Identifies jacketed, shielded, cables, even in pipe
- ◆ Easy to understand and use



**TIMCO INSTRUMENTS, LLC**

Phone: (401) 539-7120 Fax: (401) 539-6018

[www.timcoinstruments.com](http://www.timcoinstruments.com)





# Transition Couplings

## PVC Bell End Adapter

## Galvanized Rigid Conduit

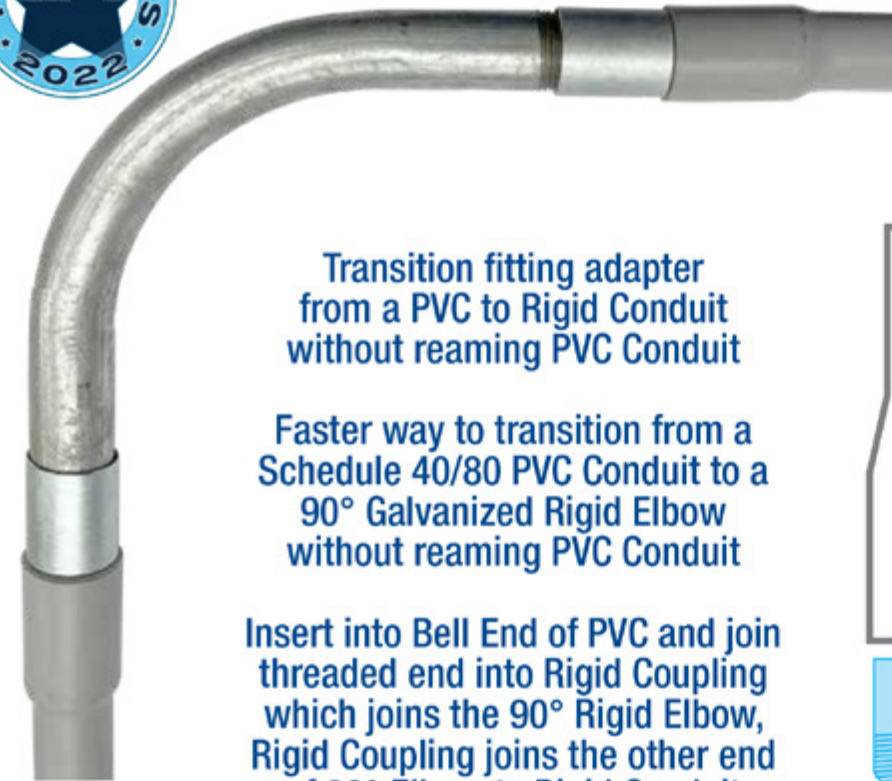

**UL** US  
 PATENT PENDING



Transition fitting adapter from a PVC to Rigid Conduit without reaming PVC Conduit

Faster way to transition from a Schedule 40/80 PVC Conduit to a 90° Galvanized Rigid Elbow without reaming PVC Conduit

Insert into Bell End of PVC and join threaded end into Rigid Coupling which joins the 90° Rigid Elbow, Rigid Coupling joins the other end of 90° Elbow to Rigid Conduit

Meets UL651 CSA CSS.L Ng83 and US Army Corps or Engineers Specs.



PVC Conduit Bell End



PBEA RGD



Rigid Coupling

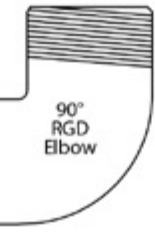

90° RGD Elbow



**1/2" thru 6"**

Transition Couplings	
Size	Catalog #
1/2"	PBEA/RGD 50
3/4"	PBEA/RGD 75
1"	PBEA/RGD 100
1-1/4"	PBEA/RGD 125
1 1/2"	PBEA/RGD 150
2"	PBEA/RGD 200
2-1/2"	PBEA/RGD 250
3"	PBEA/RGD 300
3-1/2"	PBEA/RGD 350
4"	PBEA/RGD 400
5"	PBEA/RGD 500
6"	PBEA/RGD 600

2022 **NECA**  
**Show Stopper**  
 WINNER

Customer must satisfy all codes and owners' specifications.



PATENT PENDING  
 PATENTED



LABELS APPLY TO PRODUCTS ONLY WHERE SHOWN ABOVE

**Flame Resistant Backpack from Klein Tools®  
Designed Specifically for Ironworkers and Welders**

Klein Tools, for professionals since 1857, introduces the Tradesman Pro™ Ironworker and Welder Backpack, a 27-pocket tool bag made of flame resistant 1680d ballistic weave material and designed with the professional ironworker and welder in mind.

Tradesman Pro™ Ironworker and Welder Backpack (Cat. No. 55665)

- Features 27 total pockets and a large front pocket for welding hood or hard hat
- Exterior 1680d ballistic weave and leatherette materials meet NFPA701 standards for flame resistance
- Front welding helmet pocket is removable and adjustable for easy cleaning; fits helmets of all sizes
- Outside mounted connecting bar holder (designed to fit a 24" or 36" bar) and has a wide, open interior pocket to accommodate larger tools
- Interior constructed with custom straps to hold two 18" spud wrenches and a pocket for a hammer up to 6 lbs. (2.7 kgs) with a 16" handle
- Convenient exterior water bottle pocket
- Carry a welding helmet and hard hat at the same time, while having enough room to fit additional tools, gear and safety equipment inside
- Aircraft cable heavy reinforces the handle while heavy-duty zipper with lockable pulls secures tools inside (lock not included)
- Fully molded bottom protects contents from the elements
- Orange interior for easy tool visibility



"Ironworkers and welders face a unique set of needs in carrying and transporting their tools, given the specific tools they need and the conditions they encounter on the jobsite," says Scott Rabe, senior product manager at Klein Tools. "With the new Tradesman Pro Ironworker and Welder Backpack, Klein Tools has created a bag with 27 pockets, enough to hold all necessary tools, plus the ability to fit a 24-inch to 36-inch connecting bar, welding helmet and hard hat. The ballistic weave and leatherette materials are flame resistant and built to be durable against the conditions welders face every day."

**For more information, visit  
[www.kleintools.com/new-products](http://www.kleintools.com/new-products)**



**Power Through Tough Jobsite  
Applications with the New 20V MAX\*  
XR® 1/4 in. 3-Speed Impact Driver  
that Delivers 30% More Torque\*\***

*New DEWALT XR® Impact Driver delivers immense power and efficiency with 1825 in-lbs of max torque and 3,400 RPM (no load)*

DEWALT, a Stanley Black & Decker (NYSE: SWK) brand and leader in total jobsite solutions, recently announced the new 20V MAX\* XR® 1/4 in. 3-Speed Impact Driver (DCF845) that boasts 30% more torque\*\* and is designed for tough fastening jobs on the worksite. Delivering 1825 in-lbs of max torque and 3,400 RPM (no-load) through a brushless motor, the 20V MAX\* XR® 1/4 in. 3-Speed Impact Driver is ideal for applications that demand power and efficiency.

In addition to providing power, the 3 speed modes, variable speed trigger, forward/reverse switch, and ergonomic grip help put the user in control when completing applications in various materials. With the on-tool 3-LED work light, users can illuminate dimly lit workspaces for enhanced visibility.

The 20V MAX\* XR® 1/4 in. 3-Speed Impact Driver is available now as a bare unit (tool only, DCF845B) and in several kitted options (DCF845P1, DCF845P2, DCF845D1E1) where DEWALT products are sold.

**For more information, visit  
[dewalt.com](http://dewalt.com)**

# The Heavy Duty Nonmetallic CABLE RACK

For Power and Communications Manholes And Vaults

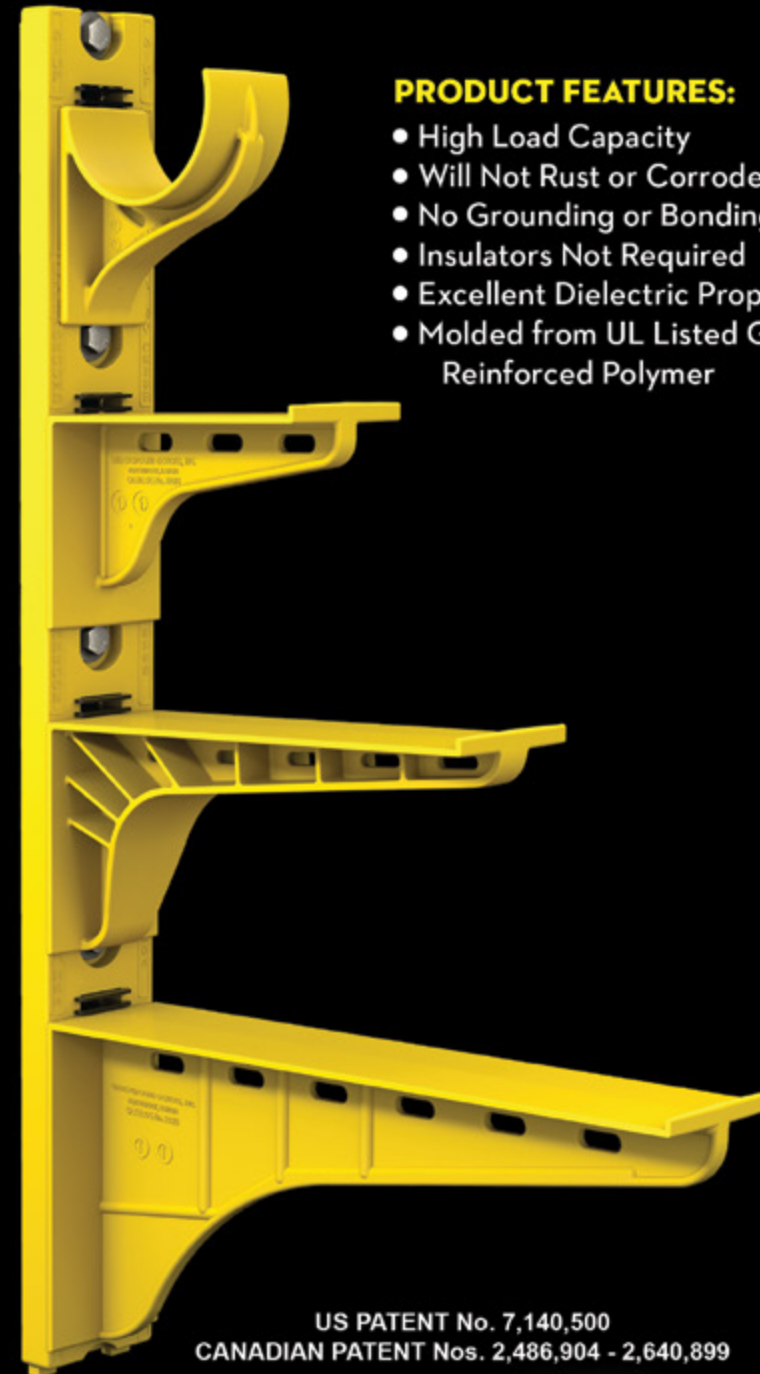

**PRODUCT FEATURES:**

- High Load Capacity
- Will Not Rust or Corrode
- No Grounding or Bonding
- Insulators Not Required
- Excellent Dielectric Properties
- Molded from UL Listed Glass Reinforced Polymer



HDL Arm Lock shown with RA04 Arm and CR36-B Stanchion



3HDS - 3" throat saddle shown with a cable secured by cable ties.



RA08 - 8" arm shown with three cables secured by cable ties.

US PATENT No. 7,140,500  
CANADIAN PATENT Nos. 2,486,904 - 2,640,899

**UNDERGROUND DEVICES**  
INCORPORATED



420 ACADEMY DRIVE  
NORTHBROOK, IL 60062  
Phone: 847-205-9000 • Fax: 847-205-9004  
Website: [www.udevices.com](http://www.udevices.com)



**WIREMOLD® dash™ Furniture Power Center**

**Configurable Furniture Power Center**

Designed to be easily installed into furniture, the dash™ Furniture Power Center provides designers a higher degree of customization while giving users easy access and control of power and data wherever it is needed. The dash product family is built around a common set of cubes that can be configured at the factory to meet the needs of any environment.

The furniture power center is ideal for hospitality spaces allowing for control of nearby devices with the built-in switching controls. The modern design allows it to compliment any space with standard device and trim plates available in white or graphite finishes. Additional trim plates are available in stainless, bronze, and brass finishes.



**Features & Benefits**

- Easy installation. All dash™ products are easy-to-install, requiring minimal hardware.
- Features tamper-resistant receptacles. Tamper-resistant receptacles protect users and devices from damage or risk of injury..
- Slim, Modern Design. The dash FPC is designed to blend right into any space, complementing existing decor with a minimalist design that's right on target with high end environments.
- Front Mount Unit. This product is required to install from the front, which is easy and flexible. Unit can be mounted vertically and horizontally.
- RoHS, Prop 65 compliant.
- Future-ready. With so many potential configurations and options, the dash™ offering is designed with the future in mind. Combine USB type A/C ports with switching and data options..
- UL Spill Water Compliant. Passed UL 962A Spill Water Test requirements so it can even be used in a horizontal surface such as a tabletop.
- FCC Compliance. This device complies with FCC Part 15, Subpart B. Operation is subject to the following two conditions: (1) this device may not cause harmful interference, and (2) this device must accept any interference received, including interference that may cause undesired operation.

**For more information, visit [legrand.us](http://legrand.us)**

**Accent on Innovation: Introducing the Accents Series, TCP's Debut Line of Decorative Lighting**

Technical Consumer Products, Inc. (TCP) – the industry leader in innovation for commercial and residential LED lighting – is excited to announce the launch of its debut line of decorative lighting, the Accents Series. Innovation has been the hallmark of TCP lighting for over 25 years, and this new line brings that wealth of experience to brilliant life for commercial and residential customers. With effortless functionality and elevated design, the Accents Series marries contemporary style to the highest standards of quality, with a full line of pendant and panel light options for commercial and residential applications.

**Accents Pendant Lights**

Modern pendant lighting is versatile, practical and useful in nearly any space. From a kitchen island to the master suite to an upscale retail boutique display, pendants offer ambient or task illumination without taking up floor or tabletop space. TCP's Accents Series offers a world of possibilities for elevating any interior design. Options include:

- **2 Styles** - Mesh pendants feature a finely woven criss-cross pattern of thin metal pieces to create a screen around the bulb that complements contemporary or transitional interiors. Rail style pendants amplify vintage-inspired or industrial-chic aesthetics with thicker metal pieces that are set farther apart, creating a cage-like appearance.
- **Spiral** - Choose Round for a more traditional look or Cylinder for an edgier vibe. Spiral Rail pendants amp up the look with a fresh twist on contemporary style.

- **3 Finishes** - Black, Silver and Gold finishes are available to complement a wide range of décor aesthetics.
- **2 Bulb Types** - The LED Lens bulb option is truly unique. This bulb sits flush with the pendant's base and creates the appearance of a softly glowing globe. The Pillar bulb resembles a retro-chic Edison bulb and is visible when the pendant is lit. Both options feature a standard E26 base that works with most socket types.

**For more information, visit [www.tcpi.com](http://www.tcpi.com)**



**CONNECT DIRECTLY TO  
AND SAFELY MONITOR  
UP TO 15KV**

**MODEL 15KVPSET VOLTAGE PROBES**

THE MODEL 15KVPSET VOLTAGE PROBES ALLOW CONNECTING POWERSIGHT POWER ANALYZERS DIRECTLY TO 3-PHASE VOLTAGES UP TO 15 KILOVOLTS. NORMALLY, PROFESSIONALS WHO WISH TO MEASURE 12,470 VOLT LINES NEED TO LOCATE OR INSTALL A PT (POTENTIAL TRANSFORMER) IN ORDER TO MONITOR MEDIUM VOLTAGES. THE 15KVPSET ALLOWS DIRECT CONNECTION OF MEDIUM VOLTAGES TO POWERSIGHT ANALYZERS. SHOWN WITH OPTIONAL HOT STICKS, THE 15KVP HAS SHEPHERD HOOKS FOR HANGING ON BARE CABLE, TAPING OR BOLTING TO BUS BAR, OR ANY OTHER CONNECTION THAT IS NEEDED. THE 15KVPSET COMES DISASSEMBLED IN ITS OWN COMPACT CANVAS CARRYING CASE.



15 KVP Voltage Probe (Single)

15KVPSet (3 Probes, 9 Hot Sticks, Case)

BUY • RENT • TRADE IN



The World's Only Medium Voltage Direct Connection Solution for Portable Power Analysis.

**Made in USA**  
with US & Imported Parts

**Products in Stock!**  
  
**Most Orders Ship in 1-2 Days!**

**advertiser**  
INDEX

This advertiser index is compiled as a courtesy to our readers. While every effort is made to provide a complete and accurate listing of companies and page numbers, the publisher is not responsible for errors. **Click the company name or page number to see their advertisement.**

Company	PG#	Company	PG#
APPLETON / EMERSON	13	RANDL INDUSTRIES	21
APPLETON / EMERSON	15	RONK ELECTRICAL INDUSTRIES	11
CONDUIT REPAIR SYSTEMS	4	SOLAHD / EMERSON	17
IToolco	IFC	SOLAHD / EMERSON	23
KRENZ & COMPANY	32	SP PRODUCTS INC	3
MILLER SAFETY CONSULTANTS, LTD	7	SP PRODUCTS INC	19
MOBILE DESK	1	SP PRODUCTS INC	26, 27
MOBILE DESK	IBC	SP PRODUCTS INC	BC
PHOENIX CONTACT USA	5	TIMCO INSTRUMENTS, LLC	25
POWERSIGHT / SUMMIT TECHNOLOGY, INC	31	UNDERGROUND DEVICES	29

When it comes to transformer cooling fans, Krenz-Vent is the industry recognized gold standard. Our leadership position is earned through 80+ years of R&D plus our superior engineering and customer service. You can rest easy when you specify Krenz fans.

**ENGINEERED TO COOL**  
There is no comparison.



**KRENZ & COMPANY, INC.**  
KRENZVENT.COM • 262.255.2310 • KRENZ@KRENZVENT.COM

**BONUS FEATURE**

**TO VISIT AN ADVERTISER'S WEBSITE, SIMPLY CLICK THE QR CODE OR COMPANY NAME IN THEIR AD.**



**AMERICAN MADE. RONK SOLID.**

**Electrical Products & Solutions**

# "When Disasters Strike, First Responders Rely On Us!"

Our complete control, communication and convenience Utility Truck Console is becoming the new standard for truck fleets of all sizes. Loaded with standard and optional features that maximize ergonomics, productivity, and fleet/telecom standards into a one exceptional Mobile Console Solution.



f YouTube t g+ in

**TOP PRODUCTS 2022**  
Electrical Products & Solutions

**MOBILE DESK**  
MOBILE OFFICE SOLUTIONS  
1-877-663-3375  
www.mobiledesk.com

Copyright © 2022 Mobile Desk, LLC. All Rights Reserved.



# SPPRODUCTS, INC.

Productivity and value thru ideas  
**FOR SAFER BETTER FASTER JOBS**



We're Proud to be the Electricians' Friend for Over 50 Years!

**IP5**

**"The Original"**

Enter Any KO on Both Sides of the Box

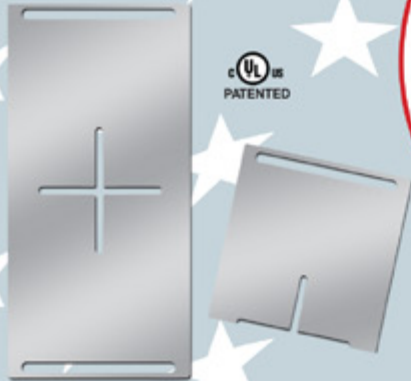

**IP19/20**

4-Conduit Block  
PATENTED

**IP21a**

QwikBlock  
PATENT PENDING

Use 4-Conduit Block (IP19 or IP20) with QwikBlock (IP21a)

**IP6d**

**2-Way** with Split Fingers for Horizontal or Vertical Installation

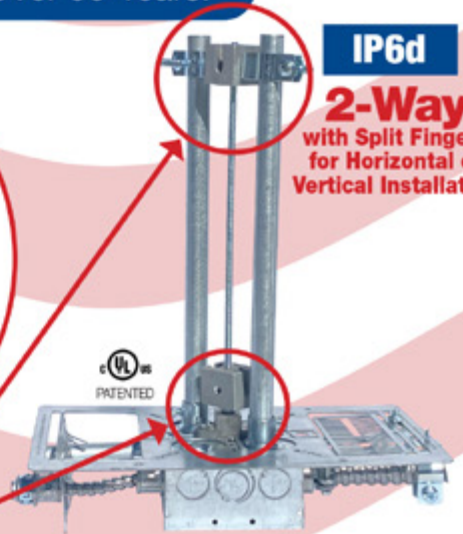

## Our Family of Conduit & Box Support Plates Saves Valuable Time & Money!



**IP6**

**4-Way**

Enter Any KO on All 4 Sides of the Box Plus 4 Large Open KOs in Center Allows Entering Back of Box

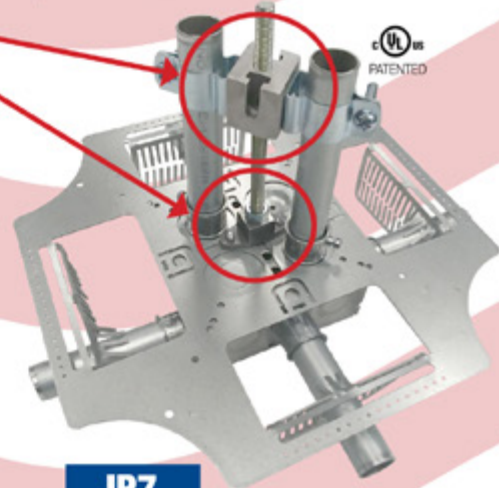

**IP7**

**4-Way**

with Split Fingers for Horizontal or Vertical Installation. Enter Any KO on All 4 Sides of the Box Plus 4 Large Open KOs in Center Allows Entering Back of Box.

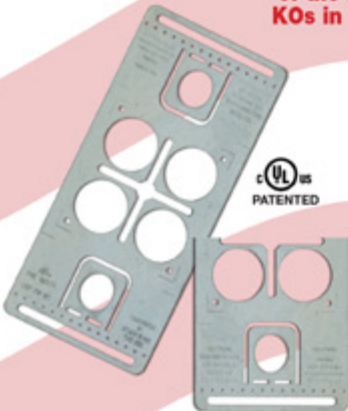

**IP6a**

**2-Way/Half**

Enter Any KO on 1 or 2 Sides of the Box Plus Large Open KOs in Center Allows Entering Back of Box

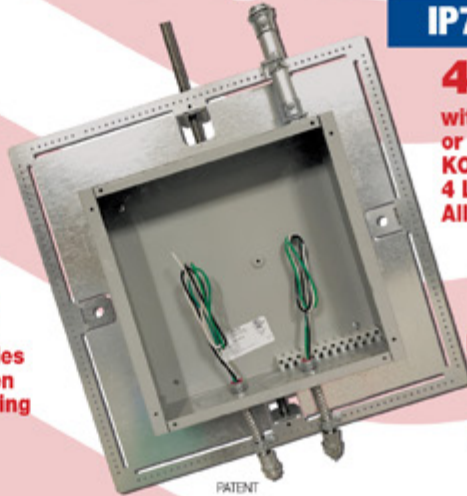

PATENT PENDING

**IP8**

Mount Horizontally or Vertically from One Single Support

**20 x 20**

Supports up to 12 x 12 J-Box

**28 x 28**

Supports up to 20 x 20 J-Box

**MADE IN THE USA!**

Plus More Being Invented for *SAFER BETTER FASTER* Jobs . . . Call With Your Ideas!

SPProducts.com **800-233-8595** info@SPProducts.com