

MARCH 2024

# Electrical

## Products & Solutions™

The Purchasing Guide for Electrical Contractors

[www.epsmag.net](http://www.epsmag.net)



### LiteLogic Lighting Controls

*Brightening the Future  
with Efficiency and Control*

# iTOOLco.

## THE MVP20K

MORE POWER, NO COMPROMISES.

865-670-3713 | www.iTOOLco.com



Picking Up and Installing a KUIKBOX  
Is as easy as 1, 2, 3!

**BUILT  
IN THE  
USA**

1   
Grab a KUIKBOX

2   
Pick Any Square Cover

# KUIKBOX

Electrical Enclosure System

3   
Install in Minutes!

## Think Simpler. Design Better.



### HOME OF THE KUIKBOX

42906 Colony Road • Olivet, S. Dakota 57052  
kuiibox@gmail.com • For more info, visit [kuiibox.com](http://kuiibox.com)



COMPANY PROFILE

**6 Protect Yourself**  
Miller Safety Consultants —  
A Leader in Arc Flash Protection

COVER STORY

**8 LiteLogic Lighting Controls**  
Brightening the Future with  
Efficiency and Control

DEPARTMENTS

- 14** INDUSTRY NEWS
- 22** NEW PRODUCTS
- 32** AD INDEX

ON THE COVER

Photo courtesy of Barron Lighting Group



**Electrical Products & Solutions™**  
The Purchasing Guide for Electrical Contractors [www.epsmag.net](http://www.epsmag.net)

PUBLISHER  
Danny J. Salchert

OFFICE MANAGER  
Anita Salchert

CREATIVE DIRECTOR  
Derek Gaylard

CIRCULATION DIRECTOR  
Pam Fulmer



PRESIDENT  
Danny J. Salchert

EXECUTIVE AND  
ADVERTISING OFFICES  
2009 Eagle Ridge Drive  
Birmingham, AL 35242  
**phone:** 205.981.4541  
[www.epsmag.net](http://www.epsmag.net)  
[danny@epsmag.net](mailto:danny@epsmag.net)

*Electrical Products & Solutions™* is published twelve times a year on a monthly basis by ABD Communications, Inc., 3591 Cahaba Beach Road, Birmingham, Alabama, 35242, USA. *Electrical Products & Solutions™* is distributed free to qualified subscribers. Non-qualified subscription rates are \$57.00 per year in the U.S. and Canada and \$84.00 per year for foreign subscribers (surface mail). U.S. Postage paid at Birmingham, Alabama and additional mailing offices. *Electrical Products & Solutions™* is distributed to qualified readers in the electrical contracting industry. Publisher is not liable for all content (including editorial and illustrations provided by advertisers) of advertisements published and does not accept responsibility for any claims made against the publisher. It is the advertiser's or agency's responsibility to obtain appropriate releases on any item or individuals pictured in an advertisement. Reproduction of this magazine in whole or in part is prohibited without prior written permission from the publisher.

POSTMASTER: Send address changes to  
ABD Communications, Inc., P.O. Box 382885  
Birmingham, Alabama 35238-2885

FOLLOW US ON



We're Proud to be the Electricians' Friend for Over 50 Years!

**Qwik Duct**  
**Safer Better Faster** IP3b

HDPE CUSTOM TEMPLATES  
In Any Configuration Required



Save on Installation!

IP1

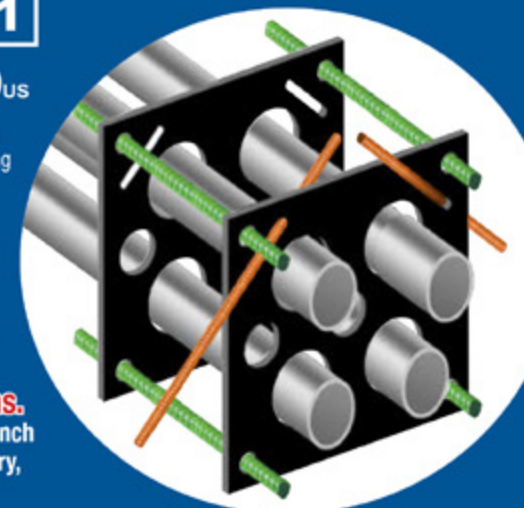

Assemble Conduit Above Trench-  
**No Workers Below -**  
**Prevents Injuries and Deaths.**  
Also Allows Digging a Narrower Trench  
for Less: Excavation, Concrete, Slurry,  
Backfill & Shoring.

PVC Offset

Sizes 1/2" thru 6"  
Meets Flexible Mandrel  
Test Requirements

Bore Spacers IP2

Sizes 1/2" thru 6"  
Roll assembled conduit into  
caissons and under  
obstructions

IP2



IP13A-F

**Conduit Transition Couplings**



PVC Schedule 40 & 80  
Transitions in Less Than  
5 Minutes

IP15

End Bell  
Adapter  
Schedule  
40/80 PVC



PVC/PVC

PVC/EMT

PVC/Rigid

PVC/Liquidtite

PVC/Stainless

PVC/Alum

PVC/Flex

IP14a

1 Piece  
Reaming Bit  
1/2" thru 6"  
Schedule 40/80

Save Cost on the Rigid Nipple, Tape & Labor  
Use for Entire Job - Not Just for Repair

Plus More Being Invented for SAFER BETTER FASTER Jobs... Call With Your Ideas!



SPProducts.com 800-233-8595 info@SPProducts.com

# REPAIR CONDUIT IN A SNAP!

No Tape • No Plastic Straps • No Metallic Straps

## NO KIDDING!

*Designed especially for power, communications and fiber optics.*



**STEP 1**  
Remove damaged conduit

**STEP 2**  
Cut split duct conduit to fit

**STEP 3**  
Snap in place

**STEP 4**  
Attach adapters

**STEP 5**  
Finish job in record time

*“The World Leader In Split Conduit Products”*



**Conduit Repair Systems, Inc.**  
The World Leader In Split Conduit Products



800.670.1804 • 435.673.8724 fax • crs@conduitrepair.com • www.conduitrepair.com

# The Heavy Duty Nonmetallic CABLE RACK

For Power and Communications Manholes And Vaults



**PRODUCT FEATURES:**

- High Load Capacity
- Will Not Rust or Corrode
- No Grounding or Bonding
- Insulators Not Required
- Excellent Dielectric Properties
- Molded from UL Listed Glass Reinforced Polymer

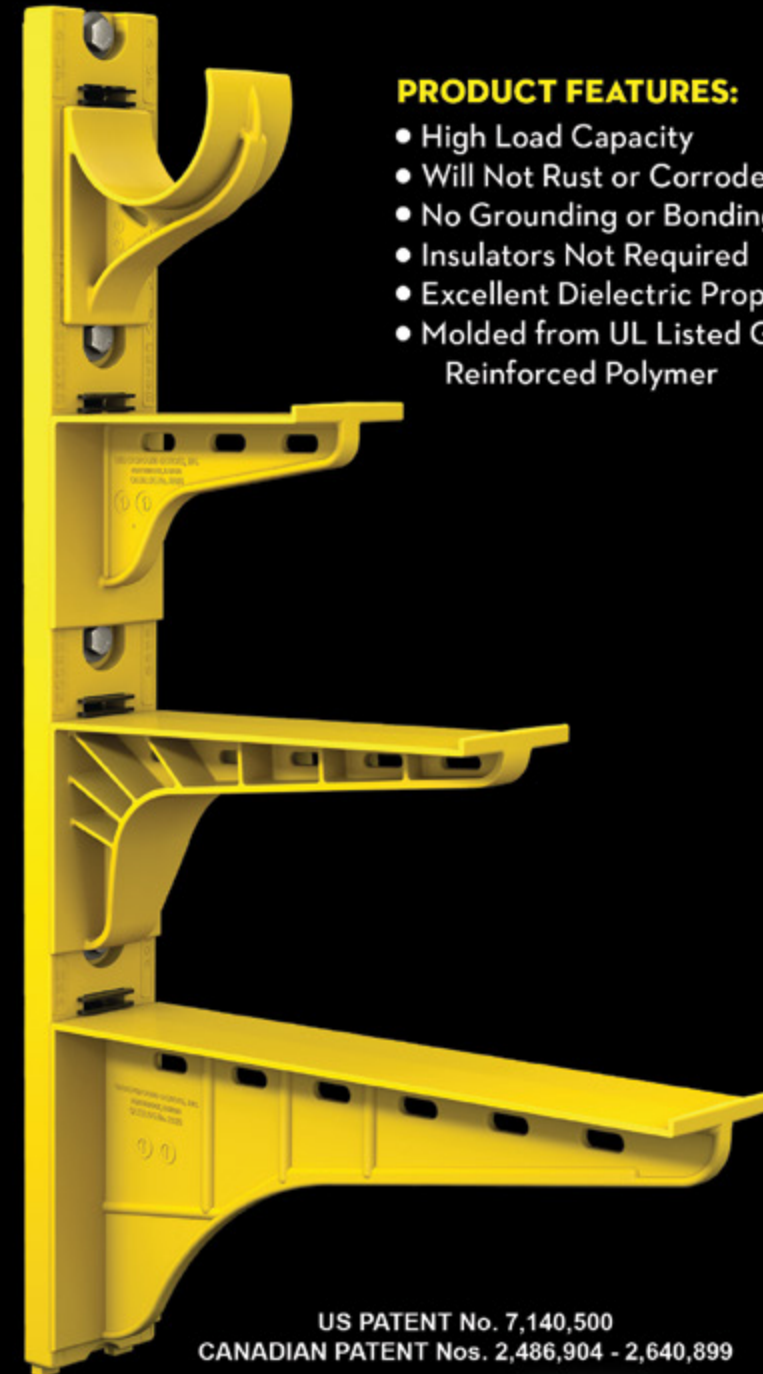

US PATENT No. 7,140,500  
CANADIAN PATENT Nos. 2,486,904 - 2,640,899



HDL Arm Lock shown with RA04 Arm and CR36-B Stanchion



3HDS - 3" throat saddle shown with a cable secured by cable ties.



RA08 - 8" arm shown with three cables secured by cable ties.

**UNDERGROUND DEVICES**  
INCORPORATED



420 ACADEMY DRIVE  
NORTHBROOK, IL 60062  
Phone: 847-205-9000 • Fax: 847-205-9004  
Website: [www.udevices.com](http://www.udevices.com)

# Protect Yourself

## Miller Safety Consultants — A Leader in Arc Flash Protection

Vince Miller started Miller Safety Consultants, a veteran owned business in 1999. The goal of the business was to provide cost effective safety consulting, employee training such as: confined space entry, fall protection, electrical safety and provide sales of electrical shock and flash protective equipment and fall protection equipment to businesses in the Washington DC area.

Reliance Industries provided fall protection products and much of the sales and training was on behalf of the supplier. In 2000, the owner decided to retire from his business, and Vince decided to discontinue the fall protection line of his business and concentrate more in the electrical training and products.

Vince had been a distributor for Certified Insulated Products (CIP), a manufacturer of electrical insulated tools and electrical arc flash clothing manufactured by Otex in Rochester, New York. As a distributor, Vince provided sales through his internet website and much through relationships with electrical contractors. His training was a classroom environment and was provided directly to customers but he also taught as a sub-contractor for other safety consulting companies and the

Chesapeake Safety Council in Baltimore, Maryland. In 2005, Vince partnered with Vivid Learning Systems in Cascades, Washington to provide on-line training in safe work practices.

Training in electrical safe work practices is still provided locally in the Washington DC area and as a partner with an electrical engineering firm and online. The training is based on the Occupational Health and Safety Administration (OSHA) standards and the National Fire Protection Association (NFPA) 70E standard.

Miller Safety Consultants is now a distributor for Cementex USA, Burlington, New Jersey, for insulated tools and equipment and clothing from OTEX Protective, Rochester, New York.

The majority of his sales of products

are from the web-based store. Cementex is nationally known for their quality equipment. Otex Protective is becoming more known for their quality clothing. For years, they have manufactured their products under other provider labels. Vince chose to not create his clothing line, but to sell the manufacturer product.

Vince has worked with many electrical company employees to fine-tune the clothing to be more comfortable for the user. Working closely with the manufacturer, they have made slight changes in how the cloth pattern was modified to meet final production. An example is the lightweight 40 Calorie vented hood offered by Otex.

The material is of the latest technology. The vented assembly is constructed for balance on the back of the hardhat and the airflow is 27 CFM to prevent fogging of the face shield and provide cooling to the worker. It took over a year to develop the product with the user prior to having the hood "flash tested". This product is now standard issue with many electrical contractors.

Being a small business and having quality providers has resulted in satisfied customers for Miller Safety Consultants. Being a direct supplier for OTEX Protective, another small business means customized customer needs can be met. □

For more information, visit  
Miller Safety Consultants at:  
[www.electricalsafety.com](http://www.electricalsafety.com), email  
Vince at: [sales@millersafetyltd.com](mailto:sales@millersafetyltd.com).

**AUTHORIZED**  
**Cementex**  
**The Safety Tool Specialists**  
**DISTRIBUTOR**

Give Vince a call at  
**(703) 367-0404**



Deluxe Maintenance Tool Kit



Class O Glove Kit

# Protect yourself from "Arc Flash"



**ARC FLASH LIFT-FRONT HOOD WITH V<sup>12</sup> HIGH-VOLUME VENTILATOR**  
Compact. Powerful. Reliable

Our V<sup>12</sup> High-Volume Ventilator boasts an unexpectedly quiet, high output (35+ CFM) turbine fan to cool and circulate the ambient air within the hood. Fully protected beneath it's durable ABS shell and added fabric layering, the V<sup>12</sup> High-Volume Ventilator isn't just compliant, it's superior.



**40 CAL/CM2 ULTRALIGHT CLOTHING BY OTEX**

Our new dual-layer Ultralight clothing takes advantage of DuPont's® dedication to scientific advancement and Westex's® industry leading dependability. Weighing in 37% lighter than traditional HRC4 PPE, our Ultralight Clothing is the most innovative contender in the lightweight arena.

**HYBRID LAYERING**

Combined Fabric Weight: 14 oz

Outer Layer: DuPont® Protera  
Color: Navy

Inner Layer: Westex Ultrasoft  
Color: Safety Orange



CALL US TODAY  
**(703) 367-0404**

OR VISIT OUR ONLINE ELECTRICAL SAFETY EQUIPMENT STORE  
[www.electricalsafety.com](http://www.electricalsafety.com)



## *Brightening the Future with Efficiency and Control*

### **Executive Summary**

Rapid advancements in lighting technology bring forth an era of higher efficiency and smart control systems that are revolutionizing the way facilities manage their lighting needs. Through the success story of the Friendship Celebration Lutheran Church in Meridian, Idaho, this whitepaper illustrates the exceptional benefits of transitioning to LiteLogic LED solutions - highlighting significant energy savings, enhanced lighting quality, and customizable control options that align with modern demands for sustainability and functionality.





BEFORE



DURING



AFTER

**Introduction**

Lighting plays a crucial role in setting the ambiance of a space, impacting functionality, productivity, and even the wellbeing of occupants. Traditional lighting solutions, like the fluorescent fixtures, have dominated the market for years but with growing energy costs and ecological concerns, institutions are now seeking smarter, more sustainable options. LiteLogic emerges as a game-changer in this realm, leveraging LED technology and Bluetooth controls to deliver superior illumination and energy efficiency. LiteLogic stands as a premium range of lighting products by the Barron Lighting Group, designed with cutting-edge features and capabilities to optimize performance while minimizing energy consumption. The solution comprises compact, long-lasting fixtures that deliver exceptional light output with minimal glare. It also incorporates Bluetooth controls for customizable scheduling and dimming options, enabling facilities to efficiently manage their lighting needs and further reduce energy costs.

**The Challenge: Outdated Lighting Systems**

The Friendship Celebration Lutheran Church, constructed in the early 2000s, faced the challenge many organizations encounter: aging lighting systems that are costly to maintain, fall short

*“The dimming capability, the uniformity, the color and the warmth of the light is so much better than what we had. I like the controllability to turn down or change the tone of the lights.”*

—Dave R, IT Manager  
Friendship Celebration  
Lutheran Church

in illumination quality, and consume excessive energy. Annual lift rentals for lamp replacements and the struggle with color matching as lamps aged or were replaced with varying LED tube retrofits also outlined the demand for a modern lighting solution. Moreover, the ability to customize lighting for different events and gatherings was an essential requirement. The church needed a reliable, sustainable lighting system with advanced controls to address these issues.

**Barron’s Solution**

MH lighting, through Katie Smith’s consultation, presented Trace-Lite’s line of sustainable and high-performing lighting fixtures to the church. By replacing existing 4-lamp T8 fluorescent fixtures with Barron’s Trace-Lite LiteLogic LED solutions on a one-for-one basis, the church achieved:

- Approximately 25% increase in foot candle levels, enhancing the brightness and ambiance of the space.
- Around 40% reduction in energy consumption, translating to cost

- savings and environmental benefits.
- Uniform color consistency across all fixtures, eliminating mismatched lighting colors.
- Integration of LiteLogic’s Bluetooth control package permitting easy dimming and scene control adjustments through a user-friendly app.

The LPX-24-CP4 fixtures played

a crucial role in facilitating these remarkable improvements. Their innovative design, coupled with the added user convenience of single-gang switches, ensured intuitive operation for individuals of all ages and technical proficiencies. QD Electrical Services went above and beyond, showcasing their unparalleled expertise and precision during the flawless

installation of the fixtures. Their unwavering commitment to exceptional workmanship and meticulous attention to detail truly set them apart in the industry.

**Implementing LiteLogic**

The adoption of LiteLogic’s integrated LED lighting and control system proved to be a seamless and minimally disruptive process for the church operations. The quick programming, completed within hours, allowed for a wide range of configurations to suit different activities within the church, spanning from worship services to engaging presentations. The versatility and efficiency of the system significantly enhanced the overall experience for both the church members and visitors.

**Benefits Realized**

**Energy and Cost Efficiency**

Trace-Lite’s LiteLogic LED solutions



Power Quality Analyzers & Loggers

**CONNECT DIRECTLY TO AND SAFELY MONITOR UP TO 15KV**

**MODEL 15KVPSET VOLTAGE PROBES**

THE MODEL 15KVPSET VOLTAGE PROBES ALLOW CONNECTING POWERSIGHT POWER ANALYZERS DIRECTLY TO 3-PHASE VOLTAGES UP TO 15 KILOVOLTS. NORMALLY, PROFESSIONALS WHO WISH TO MEASURE 12,470 VOLT LINES NEED TO LOCATE OR INSTALL A PT (POTENTIAL TRANSFORMER) IN ORDER TO MONITOR MEDIUM VOLTAGES. THE 15KVPSET ALLOWS DIRECT CONNECTION OF MEDIUM VOLTAGES TO POWERSIGHT ANALYZERS. SHOWN WITH OPTIONAL HOT STICKS, THE 15KVP HAS SHEPHERD HOOKS FOR HANGING ON BARE CABLE, TAPING OR BOLTING TO BUS BAR, OR ANY OTHER CONNECTION THAT IS NEEDED. THE 15KVPSET COMES DISASSEMBLED IN ITS OWN COMPACT CANVAS CARRYING CASE.



The World’s Only Medium Voltage Direct Connection Solution for Portable Power Analysis.



**BUY • RENT • TRADE IN**

**PowerSight.com • sales@powersight.com • 1-925-444-7027**



significantly slashed energy use, yielding considerable cost savings while fulfilling the church's commitment to sustainability.

**Improved Lighting Quality**

The enhanced lighting levels provided by Trace-Lite not only ensured better visibility and comfort for the churchgoers and staff but also created a welcoming ambiance that enhanced the overall experience within the church premises.

**Advanced Controls for Customization**

LiteLogic's Bluetooth controls are a fundamental element of the church's lighting system, providing seamless transitions between scenes and customizable dimming options. These innovative controls cater to various events and activities hosted within the church premises, enhancing the ambiance and flexibility of lighting arrangements.

**Conclusion**

The LiteLogic installation at the Friendship Celebration Lutheran Church exemplifies the profound impact advanced LED lighting solutions can have on institutions. The project was a testament to the tangible benefits of quality, control, energy savings, and the ease of transitioning to a smarter lighting system.

Any facility manager or lighting engineer witnessing the remarkable transformation at the Friendship Celebration Lutheran Church would understand the significant stride LiteLogic represents for future lighting solutions. It's not just about lighting up a space; it's about embracing technology that allows us to see clearer, work smarter, and live better. □

*For further information about Trace-Lite's LiteLogic solutions and to discuss upgrading your facility's lighting, contact your local Barron Lighting Rep or visit [barronltg.com](http://barronltg.com).*

**LIGHT UP THE FUTURE WITH LITELOGIC'S SMART CONTROLS**

Introducing LiteLogic by Barron – simple, secure, and smart lighting controls designed for versatility.

**BLUETOOTH® MESH**

TRANSMISSION UP TO 150 FEET

UNLIMITED ZONES,  
100 DEVICES PER ZONE  
No gateway, no additional equipment required.

**EASY & AFFORDABLE**

SET-UP DONE DIRECTLY  
ON YOUR SMART PHONE  
IN MINUTES

ALL FIXTURES SEAMLESSLY CONNECT AND TRANSMIT INFORMATION TO ONE ANOTHER.

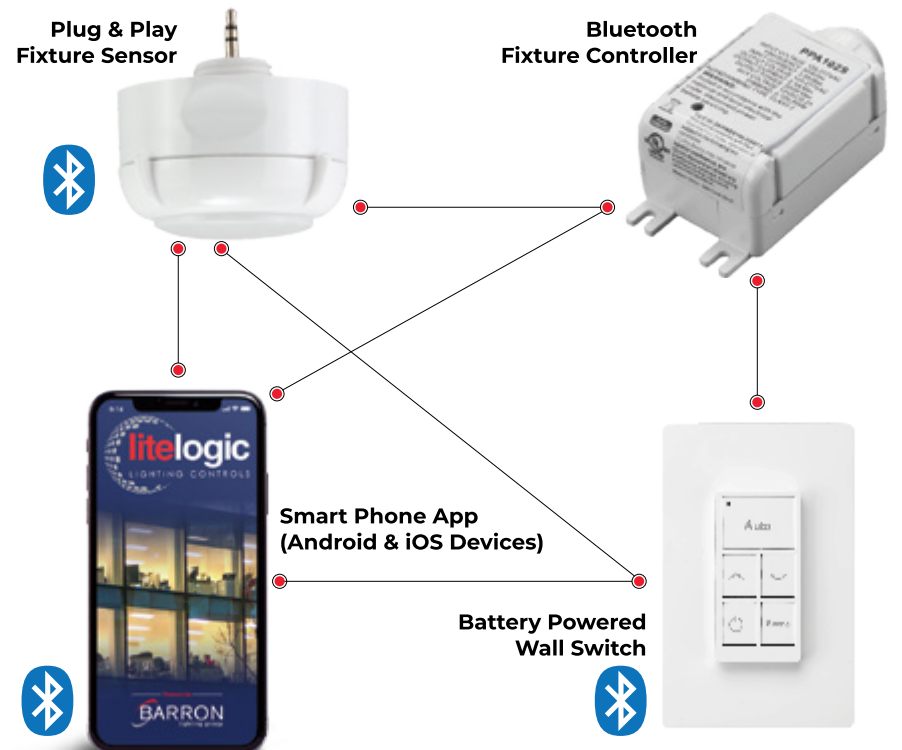

**READY TO INNOVATE?**

Contact Your Barron Lighting Rep Today!



888.533.3948 | [barronltg.com](http://barronltg.com)



# MaxLite Hires Elio Kim as Vice President, Lighting Products and Corporate Marketing

*Company strengthens commitment to LED lighting products while increasing focus on emerging technologies*

MaxLite, a leading innovator in the LED lighting industry, is pleased to announce that it has hired Elio Jin-Ha Kim as Vice President, Lighting Products and Corporate Marketing.

Kim brings over 20 years of experience in the LED lighting industry and a strong background in marketing to his new role. He will oversee the product management and engineering of indoor and outdoor luminaires and lamps, as well as the company's overall marketing. He will lead his team of product managers and engineers as well as the marketing group from the company's headquarters in New Jersey.

Prior to joining MaxLite, Kim was Head of the Lighting Marketing Group at Samsung Electronics in Korea. While at Samsung, he also worked as Principal Engineer and Head of Product Management and Application Engineering for the company's LED Business Team. He holds a Doctor of Philosophy, Electrical and Computer Engineering from the University of Texas at Austin, as well as a Bachelor's and a Master's of Science degrees in Physics from the Korea Advanced Institute of Science and Technology.

"I'm delighted to welcome Elio to our team," said Spencer Bolgard, President and Chief Executive Officer.



"Elio offers a tremendous combination of experience: deep knowledge of the LED lighting industry, solid marketing expertise and a global business perspective. His unique skillset will strengthen our ability to gain market share with our foundational products while also driving our overall growth and success."

"I'm excited to be joining the MaxLite team," said Elio Kim. "I am impressed with MaxLite's industry

leadership, its laser focus on product quality and innovation, and its deep research capabilities. I look forward to working with the engineering and product management teams to meet the challenges ahead. I'm also happy to lead the company's robust marketing team as we promote our products and services, develop relationships and advance our market position."

Bolgard continued, "With Elio on the team, we have the chance to reinforce our commitment to our LED lighting products while sharpening our focus on emerging technologies. We're reorganizing our engineering and product management department to align two complementary teams, one dedicated to our foundational LED products and the other to new technologies. With two teams in place, both committed to increasing our momentum, we are well-positioned to capitalize on our progress."

As part of the reorganization, Umesh Baheti will move into a new role. As Senior VP of New Technologies, Baheti will lead our expanding team in innovating and developing cutting-edge products to meet evolving customer needs. He will also spearhead efforts to expand MaxLite's presence into new verticals. □

## ABOUT MAXLITE

MaxLite has been committed to providing energy-efficient lighting products since 1993. One of the first movers into LED technology in the industry, MaxLite offers a complete portfolio of quality certified LED lamps, indoor and outdoor LED luminaires, and a full line of its patented c-Max Lighting Controls. As part of its commitment to providing sustainable eco-friendly solutions, the company will soon launch EVMax, a comprehensive lineup of EVSE solutions for electric cars. A five-time recipient of the ENERGY STAR Partner of the Year Award for its industry leadership, MaxLite continues to be at the forefront of energy-efficient technologies through the innovative research and development capabilities of its teams and facilities in New Jersey, Indiana, California, and globally. MaxLite is a nationally certified Minority Business Enterprise (MBE) by the National Minority Supplier Diversity Council. For more information, call 800-555-5629, email [info@maxlite.com](mailto:info@maxlite.com), or follow us on LinkedIn, Facebook, X and Instagram.



## Extend Luminaire Life While Reducing Energy Consumption

The Appleton™ Mercmaster™ Connect LED by Emerson is designed to illuminate hazardous and harsh industrial locations with integrated motion and illuminance sensors. Paired with Emerson's Plantweb Insight Connected Lighting Application, operators have access to lighting usage data and sustainability analytics.

The Mercmaster Connect LED provides facility managers with continuous monitoring of their LED lighting with real-time insights gained into sustainability goals, diagnostics and lumen levels from any remote location at dramatically lower costs as compared to wired alternatives, with faster installation time and minimal disruption to plant operations.

Learn more at: [masteringled.com](http://masteringled.com)



Appleton™ Mercmaster™ Connect LED

APPLETON™

The Emerson logo is a trademark and a service mark of Emerson Electric Co. © 2021 Emerson Electric Co.



CONSIDER IT SOLVED™

# Stevens Appointed VP of Marketing and Digitalization for the Americas

WAGO has named Sy Stevens as their new Vice President of Marketing and Digitalization for the Americas. Sy brings a wealth of experience to WAGO having held marketing management positions at companies such as Rockwell Automation and Case IH.

With operations in the United States, Canada, Mexico and South America, he will be leading and implementing strategic marketing initiatives across

North and South America. "I am excited for the opportunity of working alongside the innovative and talented people at WAGO corporation while empowering customers to experience the WAGO difference," says Stevens. Besides continuous growth, Sy's main goal is to build a brand customers have confidence in knowing their expectations are met and ultimately exceeded.

Welcome to WAGO, Sy!



## ABOUT WAGO

Innovation is at the heart of everything we do at WAGO. From our pioneering CAGE CLAMP® spring pressure connection technology to our extensive range of Interconnect, Interface and Automation solutions, such as the fieldbus independent WAGO-I/O-SYSTEM, our customers count on the unconditional performance and reliability of our products to ensure the safe, efficient operation of their systems every time. For additional information, visit [www.wago.us](http://www.wago.us). Contact WAGO at 1-800-DIN-RAIL or [info.us@wago.com](mailto:info.us@wago.com).



Power Quality Analyzers & Loggers

## MONITOR ANY POWER SOURCE OR LOAD



Compact full-featured Power Quality Analyzer for all your needs

SCAN ME



COMPACT - CAPABLE - VERSATILE  
POWER ANALYZERS

IT'S ALL WE DO.

BUY • RENT • TRADE IN

- VERIFYING BACKUP POWER
- LOAD STUDIES
- COST & ENERGY ANALYSIS
- 100V - 4160V MOTORS
- POWER QUALITY
- COMMISSIONING
- HARMONIC DISTORTION
- PREDICTIVE MAINTENANCE
- DC POWER TESTING
- 400HZ MONITORING
- AND MUCH MORE



Products in Stock!



Most Orders Ship in 1-2 Days!

[PowerSight.com](http://PowerSight.com) • [sales@powersight.com](mailto:sales@powersight.com) • 1-925-444-7027

# KUIKBOX

MADE  
IN THE  
USA

"When using KUIKBOX, it changes how you think about electrical installations."

Cut the time and hassle of electrical installation by over 65% with KUIKBOX. Whether you're doing a commercial project or simply working at home, KUIKBOX can make the job easier, faster and more cost-effective.



Comes with two-pre-installed ground screws to accommodate an optional ground/lug bar



Includes brackets for installation on steel-lined walls



Any square cover can be installed on KUIKBOX

Optional dividers allow for multiple voltages in one KUIKBOX



KUIKBOX is perfect for making a clean and professional-looking electrical installation and allows for quick expansion and add-ons after the project is complete.

KUIKBOX Electrical Enclosure Systems are available in six spacious box sizes.



KUIKBOX is designed to be used with ANY generic electrical square cover.



- 2 Gang
- 4 Gang
- 6 Gang
- 8 Gang
- 10 Gang
- 12 Gang

## HOME OF THE KUIKBOX

42906 Colony Road • Olivet, S. Dakota 57052  
[kuiibox@gmail.com](mailto:kuiibox@gmail.com) • For more info, visit [kuiibox.com](http://kuiibox.com)

# Jim Thivierge Joins NSI Industries as Building Technology Division Director of Operations

*Thivierge Will Oversee the Unit's Operations in California, Ohio, and Pennsylvania and Will Report to David DiDonato, Building Technology Business Unit President*

NSI Industries, LLC is proud to announce that James (Jim) Thivierge has joined the company as director of operations for its Building Technology division. Thivierge will oversee the unit's operations in California, Ohio, and Pennsylvania and will report to David DiDonato, Building Technology Business Unit President.



(GCG), most recently serving as director of operational excellence and customer experience. He also oversaw

“Jim is a seasoned operations professional with a diverse background in sales, manufacturing, distribution, production and more,” said DiDonato. “He is an exceptional leader with a collaborative and team-first approach that will be a tremendous asset to Building Technology as we continue to evolve the business and best support the growing needs of our customers.”

With a bachelor's degree in corporate finance from Southern New Hampshire University, Thivierge joins NSI after more than 17 years at Allied Wire & Cable, a part of Genuine Cable Group

the operations of all the company's satellite branches. Prior to his time at Allied Wire & Cable, he held several roles at both Anixter and Anicom.

“NSI is an outstanding company with many dynamic brands and a strong culture based on values that I believe in, and I'm especially thrilled to join the team at such a pivotal time as it continues to transform and experience impressive growth,” said Thivierge, who is based in North Wales, Pennsylvania.

NSI Building Technologies, a part of NSI's Electrical Division, is a leader in fiber and copper cable assemblies, pigtails, connectors, patch cords, patch panels, trunks, enclosures, jacks, electronics and components for networking applications, and interconnects, AV cable, USB cables and signal distribution electronics for networking, security & AV applications.

For more information, please visit [www.nsiindustries.com](http://www.nsiindustries.com).

**“Jim is an exceptional leader with a collaborative and team-first approach that will be a tremendous asset to Building Technology as we continue to evolve the business and best support the growing needs of our customers.”**

— David DiDonato, Building Technology Business Unit President

## ABOUT NSI INDUSTRIES, LLC

NSI's core philosophy is Making Connections. Focused on the electrical, building technology, and HVAC markets, NSI connects distributors to products, services, and technologies by providing a fresh perspective and caring approach that drives smart solutions. The driving force behind a stable of market-leading brands and a large breadth of products, the company's primary job for more than 45 years has been to fulfill the needs of distributors and their customers. By staying grounded in the principles of service and value, NSI continues to deliver high-quality, industry-advancing, and comprehensive product solutions that enable growth.

NSI has many well-respected brands, including Bridgeport Fittings®, Remke Fittings®, Polaris® Power Connectors, TORK® Timers and Controls, Metallics™ Fasteners, Platinum Tools® Network Connectors, Lynn™ Network Components, ENET Solutions, Inc., Duro Dyne® Air Duct Solutions and SUPCO HVAC Repair Products. For additional information about NSI Industries and our family of brands, visit [www.nsiindustries.com](http://www.nsiindustries.com).



**SPPRODUCTS, INC.** MADE IN USA

*Productivity and value thru ideas*

**FOR SAFER BETTER FASTER JOBS**

*We're Proud to be the Electricians' Friend for Over 50 Years!*

**IP15a**  
**Chamfer Bit**  
for PVC SCH 40/80

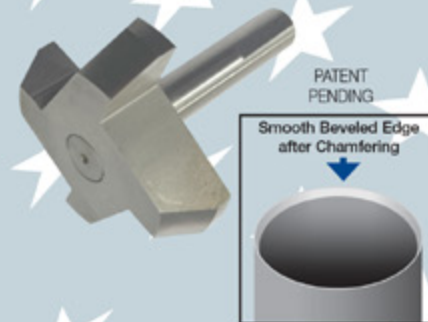

**IP27b**  
**Electro Post EP-10**  
Box Support Bracket



**IP15b**  
**Chamfer Bit**  
for Aluminum EMT

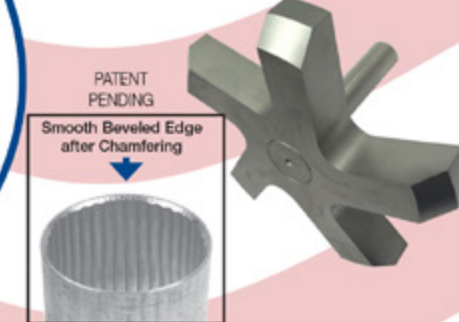

**NEW PRODUCTS**

**4-WAY CONDUIT & BOX SUPPORT PLATE with Split Fingers for Horizontal or Vertical Installation**

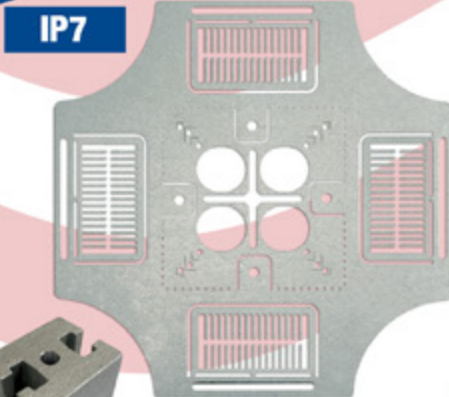
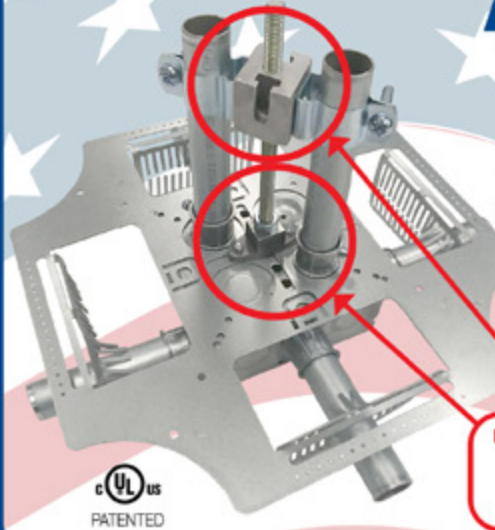

**IP19/20**  
4-Conduit Block  
PATENTED

**IP21a**  
QwikBlock  
PATENT PENDING

**PVC Running Thread SCH 40/80 Up to 30" Long**

**IP3d**



**NEW Transition Fittings**  
Saves a Great Deal of Time Repairing Conduit  
The Inside Diameter Remains the Same  
Allows for Trouble Free Wire and Cable Pulls

**IP13k**  
Inside PVC to Inside PVC  
PATENT PENDING

**IP13p**  
3/4" MC Cable to PVC



**IP13q**  
PVC Reducer  
PATENT PENDING

**Male Threaded PVC Offset**

**IP3c**

1/2" thru 3" Offset for Conduit Sizes 1/2" thru 6"  
PATENT PENDING



*Plus More Being Invented for SAFER BETTER FASTER Jobs . . . Call With Your Ideas!*

**SPProducts.com 800-233-8595 info@SPProducts.com**

# Custom Stainless Enclosures Receives ISO 9001 Quality Management Certification

*Demonstrates Commitment to Delivering Superior  
Products and Services to Customers*

Custom Stainless Enclosures, Inc., a leading manufacturer of high-quality, custom-built stainless steel electrical enclosures for extreme indoor and outdoor environments, is proud to announce that it has been awarded ISO 9001 certification. This achievement reflects the company's unwavering commitment to delivering superior quality products and services to its customers.

The ISO 9001 certification, an internationally recognized standard for quality management systems, validates Custom Stainless Enclosures dedication to continuous improvement, customer satisfaction, and operational efficiency. The certification process involves rigorous audits and assessments that scrutinize every aspect of a company's operations, from organizational structure and strategic planning to customer satisfaction and quality assurance.

"We are immensely proud to have earned ISO 9001 certification. It underscores our commitment to maintaining the highest standards in our processes and products," said Jeff Ellingson, CEO of Custom Stainless Enclosures. "This certification assures our customers that we are dedicated to providing them with the best quality products and services."

This achievement is a significant milestone in Custom Stainless



Enclosures continued growth and reinforces its position as a trusted provider of stainless steel enclosures. The company looks forward to utilizing this certification to further enhance its quality assurance procedures, improve customer satisfaction levels, and expand its market reach.

Custom Stainless Enclosures is renowned for its high-quality products, particularly the 4Xxtreme® Enclosures. These enclosures feature innovative Double Seal and Double

Stud® Mounting Technology, ensuring durability and resilience in challenging environments. With their ultra-clean free-draining design, these enclosures are not only easy to maintain but also maintain high sanitary standards. They are suitable for various industries, including food, pharmaceuticals, oil and gas, and wastewater management.

To learn more about Custom Stainless Enclosures and the 4Xxtreme® Double Seal Enclosures please visit <https://4xxtreme.com>. □



## Create a More Productive Environment with Retrofit Solutions

The Appleton™ Retromaster LED Series by Emerson is designed to upgrade outdated legacy lighting fixtures to LED to improve operational life and lower maintenance costs. Safely illuminate Class I, Division 2 locations with models providing up to 5000 lumen output in a compact footprint. With dual lumen outputs, the Retromaster LED provides a tailored retrofit solution for your facility.

Learn More at: [www.masteringled.com](http://www.masteringled.com)



Appleton™ Retromaster  
LED Series Luminaires

### ABOUT CUSTOM STAINLESS ENCLOSURES

Custom Stainless Enclosures, Inc. is an innovation leading manufacturer of electrical enclosures for the food, pharmaceutical, oil and gas, and wastewater industries, among others. Custom Stainless Enclosures is the proud manufacturer of 4Xxtreme® Enclosures – the newest innovation in the electrical enclosure industry. For the past ten years, Custom Stainless Enclosures has dedicated its time, knowledge, and effort to developing a revolutionary product that will change the way the industry views electrical enclosures. Visit <https://4xxtreme.com/> or call (651) 500-3650 for additional information.

**4Xxtreme®**

**4XProtect®**

**APPLETON™**

The Emerson logo is a trademark and a service mark of Emerson Electric Co. © 2024 Emerson Electric Co.

  
**EMERSON™**

**Custom Stainless Enclosures Highlights  
4Xxtreme® Double Seal Enclosures™**

*Built to withstand extreme conditions while maintaining peak sanitation standards*

Custom Stainless Enclosures, Inc. continues to innovate and lead the industry with the highest washdown standards for electrical enclosures, highlights its 4Xxtreme® Double Seal Enclosures for extreme indoor and outdoor environments. The 4Xxtreme® Enclosures feature patented Double Seal and Double Stud® Mounting Technology, an ultra-clean free-draining design, an award-winning “Single Hygienic Quarter Turn Door Design”, and a field replaceable blue gasket system, resulting in a revolutionary enclosure that leads the industry in the lowest overall cost of ownership and is ideal for all industries including food, pharma, oil and gas, and wastewater.

4Xxtreme® Double Seal Enclosures are UL Type: 4X rated, with additional ratings of IP66 & IP69K. Custom Stainless Enclosures is the first company in North America to Manufacture IP69K (High Pressure Wash-Down) rated enclosures. All Custom Stainless Enclosures’ washdown ratings have been 3rd party tested and verified by UL.

All 4Xxtreme® Double Seal Enclosures also feature a field replaceable blue gasket system, an easy-to-install “Push On” style gasket that requires minimal installation labor. The gasket system is made from an EPDM material that’s highly chemical-resistant and can handle consistently high temperatures of 250°F (121°C). In addition, because the gasket material is blue, all 4Xxtreme® gaskets are considered “Foreign Material Detectable”.

All 4Xxtreme® Double Seal Enclosures also feature a 2021 Process Expo Innovation Award-winning “Single Hygienic Quarter Turn Door Design”. The biggest problem with electrical enclosures in processing plants is people don’t turn all the quarter turns to properly close an enclosure door. By minimizing the number of door closure points to “One”, this design reduces premature electrical failures, increases plant production and revenue, and reduces the overall cost of equipment ownership.

4Xxtreme® patented (welded in place) Double Stud® Mounting System provides secure mounting for the back panel on the inside, while also providing an external mounting means from the outside which eliminates any need for mounting gaskets. This system also simplifies the installation process, which reduces their customers cost of installation labor and the overall cost of ownership.

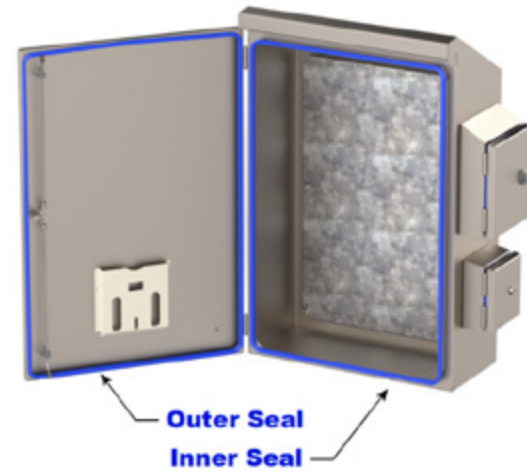

Outer Seal  
Inner Seal

**For more information, visit  
<https://4xxxtreme.com>**



**Greenlee® Pull Connect™: Intuitive,  
Synchronized Cable Pulling Solution**

*Cable pulling accessory enhances team communication for improved job site pulls*

Greenlee®, a part of Emerson’s professional tools portfolio, recently introduced Pull Connect™, a pulling accessory with a simple, intuitive operation that wirelessly synchronizes both sides of a cable pull and allows it to be stopped from either side. This easy-to-use design allows cable pulling operators to focus on the pull for enhanced safety and confidence on the job site.

“Our team regularly hears from electrical contractors that team communication is their number one safety concern when pulling cable,” said Alex Carey, product manager, Greenlee for Emerson. “The Greenlee Pull Connect addresses those concerns with its ability to

synchronize a pull, extend the signal and provide wireless communication.”

Pairing with existing Greenlee pulling equipment and designed to communicate through walls, floors and other obstructions for a synchronized pull, Pull Connect units are interchangeable, allowing them to be used in all modes (pull side, feed side and optional repeater). To help assure reliable communication, it can connect up to two repeaters, making it adaptable to nearly every job site.

Pull Connect is controlled by a foot switch for hands-free operation and provides visual cues to ensure noise is not a factor during pulls. A quick-stop button on the Pull Connect also allows the users further control of the pull. A water-resistant case and internal antenna protect from job site conditions and moisture, while its magnetic backing enables quick and easy mounting to pulling equipment.

**For more information, visit  
[www.Greenlee.com](http://www.Greenlee.com)**

# MADE IN AMERICA, FOR AMERICA

At Electri-Flex, we are proud to do our part in rebuilding America by providing top-quality, domestically sourced conduit made right here in the U.S. Our industry-leading Liqueatite® flexible conduit line is second to none, offering options for virtually every application, from data and defense to transit, rail and bridges. And backed by more than 65 years of family ownership, we look after your business as if it were an extension of our own. Because we believe that America deserves the best.

**Electri-Flex.**  
*Rebuilding our infrastructure  
at every turn.*

**DISTRIBUTORS NATIONWIDE**

**ALL PRODUCTS PROUDLY  
MADE IN THE USA**



**electri-flex**



**ELECTRI-FLEX COMPANY**

222 West Central Ave  
Roselle, IL 60172-1994 USA

Toll-free phone (U.S.): (800) 323-6124  
Phone: (630) 529-2920

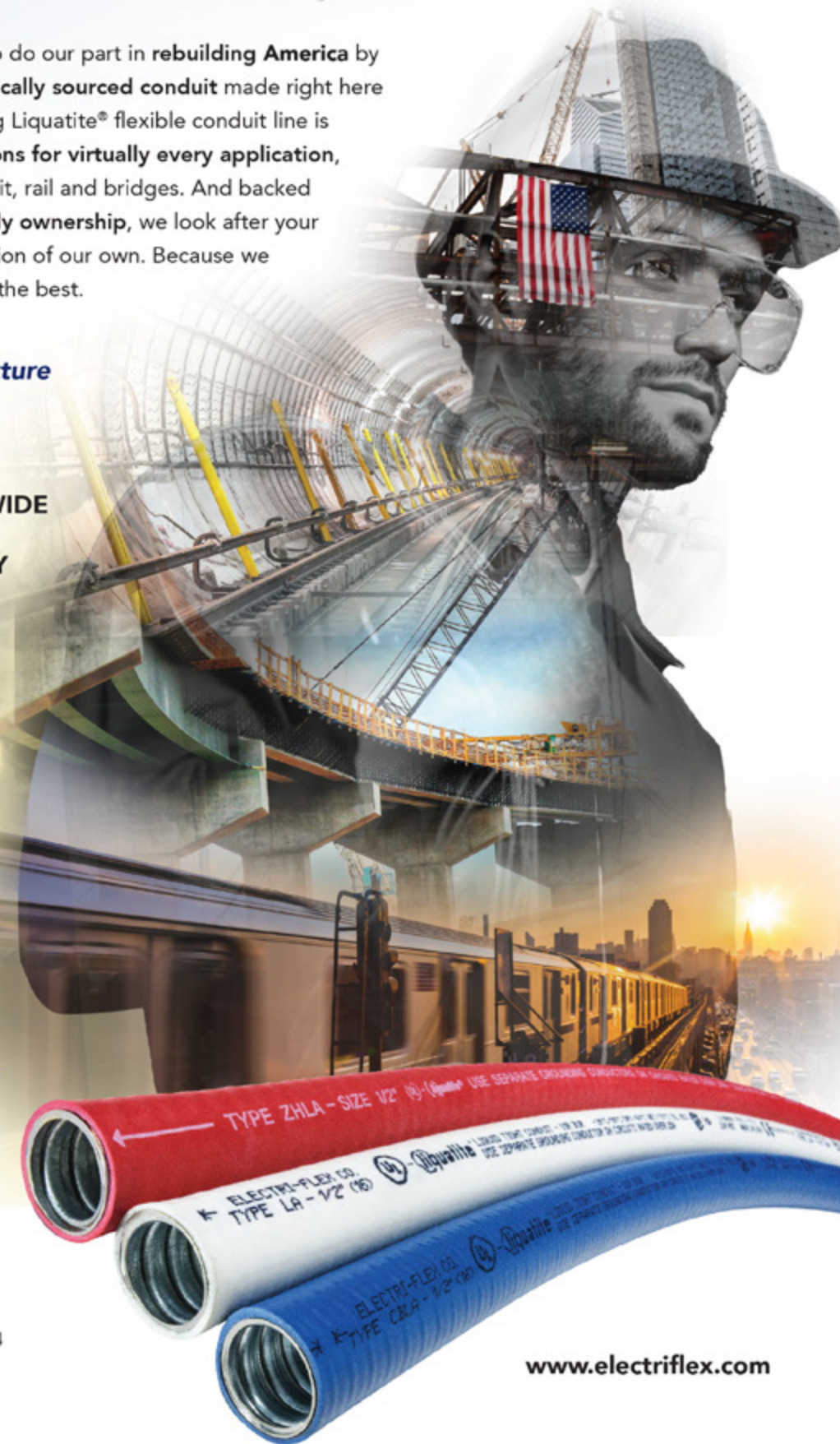

[www.electriflex.com](http://www.electriflex.com)

**DMF Lighting Launches Illuminated Room Signage for Multifamily, Hospitality, Healthcare and Other Mix-Use Spaces**

- Customizable faceplate orientation, text location and color provides flexibility to compliment décor
- Integrated driver allows for straight-forward installation and simplified serviceability
- Meets ADA Compliance with Braille for the visually impaired to meet more applications



DMF Lighting, a leading architectural lighting manufacturer of premium modular LED downlighting systems, continues to expand its hospitality and multifamily portfolio with the introduction of the A Series, a sleek, ADA compliant illuminated room sign offering complete customization including the choice of orientation, text alignment and faceplate color.

“We’re excited to offer the design community customizable illuminated signage that is ADA compliant to meet and compliment more application needs,” said Ken Czech, vice president of new product development, DMF Lighting. “And as with all DMF products, we’ve integrated the driver to simplify installation and serviceability, saving time and money.”

Specifically tailored for multifamily, hospitality and healthcare applications including apartments, condominiums, student housing, senior living spaces, hotels and patient rooms, among other mix-use spaces, the modular design features an integrated driver – versus remote – allowing for straight-forward installation and simplified serviceability. The modularity of the signage allows the frame and electrical components to ship separately so that the frame and components can be installed first and the faceplate later, reducing on-site storage requirements while maintain tight project deadlines.

Featuring a thin design with only a ½-inch depth, the surface-mount A Series rectangle sign is 7-1/4 inches by 4-1/2 inches and can be mounted either Landscape or Portrait orientation. Text alignment can be positioned in any of the four upper/lower corners. Text is elegantly illuminated through a clear, diffused lens with current fonts choices of traditional Helvetica or modern Proxima Nova. The standard faceplate color is Black, but designers can choose any custom color (RAL) to compliant their project’s décor.

The 120-volt LED signage is offered in 2700K and 3000K color temperatures with a superior 93+ coloring rendering index (CRI). Color variation is kept within a 3-step MacAdam ellipse for unparalleled quality and consistency.

Featuring Braille to meet ADA compliance for the visually impaired, the A Series signage is also compliant with California’s Title-24, ENERGY STAR® and listed for damp locations.

**For more information, visit  
[www.dmflighting.com](http://www.dmflighting.com)**

**MILWAUKEE® Introduces TORCH™ with NITRUS CARBIDE™ Blade For Medium Metals**

Milwaukee Tool continues to enhance user experience with the launch of the new MILWAUKEE® TORCH™ with NITRUS CARBIDE™ Blade for Medium Metals. These blades offer a best-in-class cutting solution for medium metal applications by delivering the fastest cuts and longest life.

The NITRUS CARBIDE™ Medium Metal Blade has unmatched life in conduit and strut, allowing users to get more done with fewer blade changes throughout their workday. With a longer life, users reduce the number of trips spent purchasing replacement blades, saving time and money. This solution delivers increased performance versus carbide blades alone in medium-thickness metals such as Conduit, Strut, Angle Iron, and Stainless Steel. Engineered to dissipate heat better than any other demolition blade on the market, these blades deliver the fastest and smoothest cuts. NITRUS CARBIDE™ offers a disruptive performance for electricians, plumbers, and mechanical contractors by providing smooth, clean cuts with its 10TPI SAWZALL® blade.

Milwaukee also introduces their new TORCH™ with Carbide Teeth for Medium Metal Blades. The blade’s Carbide Teeth technology allows users to cut faster, cut more, and cut longer in medium metal applications. With a 50X Longer Life versus Bi-Metal Blades, this solution delivers longer, smoother and faster cuts in EMT Conduit, Strut, Rigid Conduit, Stainless Steel Pipe and Stainless-Steel Strut.

The new additions within the TORCH™ family lineup continue to deliver the ultimate performance in a range of metal applications from thin to thick metals. Milwaukee is committed to innovative solutions for trade professionals and is continually setting standards in jobsite efficiency and safety.

**For more information, visit  
[www.milwaukeetool.com](http://www.milwaukeetool.com)**



**Affordable test equipment for 2024**



**Spitifire** - Buried Low Voltage Cable Fault Locator

- ◆ Accurate
- ◆ Easy to use
- ◆ High energy output
- ◆ Proven reliability
- ◆ Compact design
- ◆ Lightweight

**Wayfind'r** - Impulse cable tracer

- ◆ Accurate
- ◆ Easy to use
- ◆ Connects directly to energized cables
- ◆ Distinct signal for easy tracing
- ◆ Traces direct buried and cables in conduit
- ◆ Rugged, compact design

**Impulse Phaser** - Cable / phase system

- ◆ Accurately identifies cables in trenches, vaults, conduits and enclosures
- ◆ Accurately identifies phases in multi-conductor cables
- ◆ Identifies jacketed, shielded, cables, even in pipe
- ◆ Easy to understand and use



**TIMCO INSTRUMENTS, LLC**

Phone: (401) 539-7120 Fax: (401) 539-6018

[www.timcoinstruments.com](http://www.timcoinstruments.com)





# EZ Stub-Up SUPPORT BRACKET

- Support and secure multiple conduits and sizes with brackets and/or uni-strut at a single stub-up location
- Use nylon wrap around conduit straps, minerllacs, one-hole straps or Ty wraps to secure conduit to bracket or uni-strut
- 16 guage galvanized steel
- SUITABLE FOR 1/2", 3/4" or 1" PVC SCH 40/80 Stub-Ups

**INSTALLATION:**

1. Position bracket on deck before the concrete pour
2. Fasten bracket to deck
3. Secure conduit to bracket or uni-strut with nylon wrap around conduit straps, minerllacs, one-hole straps or Ty wraps
4. Pour slab

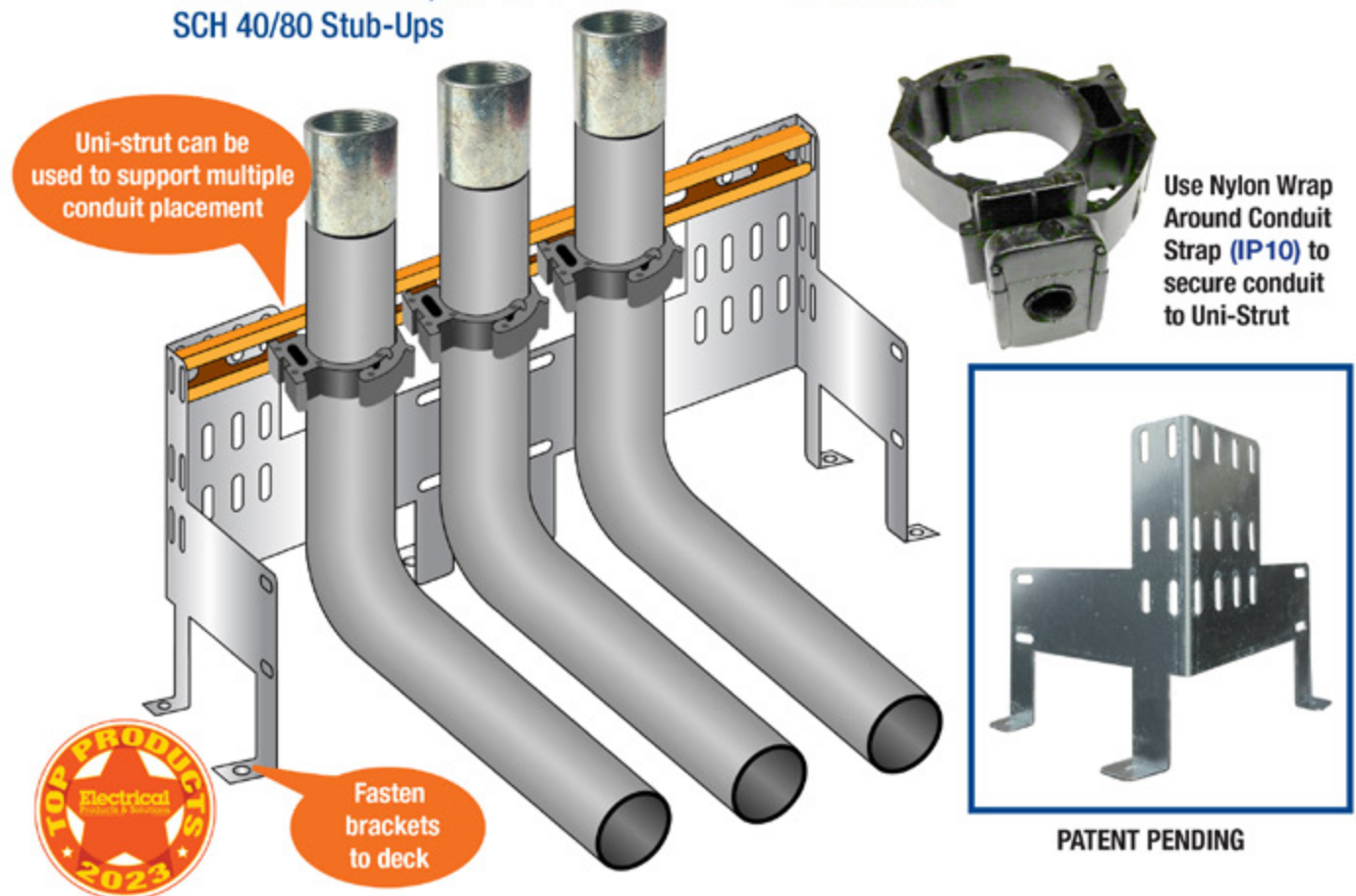

2023 NECA  
**Show Stopper**  
 WINNER



**Perfect for Poured Precast Decks!**



PATENT PENDING  
 PATENTED

LABELS APPLY TO PRODUCTS ONLY WHERE SHOWN ABOVE



**new**  
PRODUCTS

**Mitsubishi Electric Automation, Inc. Launches R86TB High-Performance Teach Pendant for Improved Operability**

The R86TB Teach Pendant can handle a series of processes from setup to maintenance, relieving the need for an on-site computer to reduce time and costs.

Mitsubishi Electric Automation, Inc.'s new teach pendant, R86TB, evolved from the conventional, high-performance teach pendant to deliver customizable and intuitive functions to OEMs and end users alike. The R86TB is designed with a 10.1-inch high-definition display so that any function can be easily visible and accessed from the customizable HOME screen or page list. Major functions of MELSOFT RT ToolBox 3, Mitsubishi Electric's PC-based robot programming software, are accessible and equipped to provide program support functions, parameter and program screens, 3D monitoring, and more.

Additional features of the R86TB Teach Pendant include data analysis and real-time monitoring to perform trouble diagnosis, secure hardware buttons for tactile and consistent operation, improved processing speeds, and security functions. Compatible with CR800 and CR700 series Controllers, R86TB allows customers increased visibility and operability to ensure smooth operations and high performance.

"We are very confident that our customers will benefit from the enhanced functionality, durability, and performance that the R86TB provides. The large, high-definition display makes it possible to make program revisions without needing to bring a laptop onto the manufacturing floor. We have designed it to be backward and forward compatible so that it can be used on older CR700-controlled robots as well as our current and future generations of robots," said Patrick Varley, Product Marketing Manager (Robot) at Mitsubishi Electric Automation, Inc.



For more information, visit <https://us.mitsubishielectric.com>

**Cementex Highlights Range of T-Handle Tools Including Hex Wrenches, 6-Point Socket Wrenches, and Drivers**

*T-Handles provide superior grip and rigid construction for evenly distributed pressure*

Cementex, the safety tool specialists, highlights the availability of its T-Handle Driver Tools, including Hex Head Wrenches, 6-Point Socket Wrenches, and Drives. All of the T-Handle tools incorporate the superior Cementex 2-layer insulation system and solid core handle to distribute pressure evenly through the gloved hand. Made in the USA featuring hardened American steel, the T-Handle tools rigid construction prevents twisting and flexing while providing the quality customers rely on from Cementex as the industry leader.

The T-Handle Hex Wrenches are available in multiple shaft lengths and a range of combinations in order to meet

each application's unique insulated hand tool needs. The wrenches can be purchased individually or in kits, and can be added to custom Cementex insulated hand tool kits. Additionally, the T-Handle 6-Point Socket Wrenches and Drives are available in a range of sizes and lengths to meet users' needs.

For more information, visit [www.cementexusa.com](http://www.cementexusa.com)



THE SECRET TO

# UNDERGROUND POWER TRANSMISSION

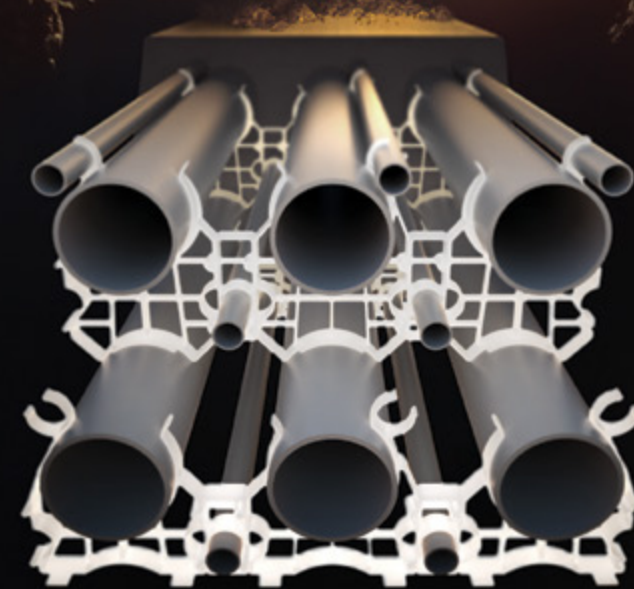

OUR WUNPEECE TRANSMISSION SPACERS REDEFINE THE INDUSTRY STANDARD FOR UNDERGROUND POWER TRANSMISSION INSTALLATIONS. WITH PRECISION ENGINEERING AND UNMATCHED QUALITY,

JOIN THE RANKS OF INDUSTRY LEADERS WHO TRUST UNDERGROUND DEVICES FOR THEIR POWER TRANSMISSION NEEDS.



VISIT [WWW.UDEVICES.COM](http://WWW.UDEVICES.COM)

AND EXPERIENCE THE FUTURE OF UNDERGROUND POWER INSTALLATION



**LEDVANCE An Industry First Innovation that Redefines Flexibility in Outdoor Area Lighting with its Field Adjustable Distribution. No Lens Swap Needed.**

LEDVANCE is excited to unveil its newest innovation in outdoor lighting the OPTI-SELECT AREA LIGHT, marking a groundbreaking advancement.

This product introduces an industry-first feature: OPTI-SELECT - Field Adjustable Distribution. Offering field adjustable distribution without the need for lens changes, embodying unmatched versatility and simplicity.

Ligia Orlandini, Product Manager at LEDVANCE, passionately articulates the distinct advantage of the OPTI-SELECT AREA LIGHT, stating: "The OPTI-SELECT AREA LIGHT is a testament to LEDVANCE's commitment to pushing the boundaries of technology and design. Our product revolutionizes the outdoor lighting experience by offering an industry first level of adaptability and convenience."

"Unlike other options on the market, that require manual lens changes, the OPTI-SELECT AREA LIGHT simplifies field adjustments with a mere turn of a switch. This means no more lens swapping, no tools required, and no risk of compromising IP65 ratings due to repeated handling. We're proud to offer a solution that not only saves time but also enhances the integrity and reliability of your lighting installations."

The LEDVANCE OPTI-SELECT AREA LIGHT stands out by integrating the innovative Field Adjustable Distribution technology, allowing for seamless switching between Type III, IV, and V distributions without changing lenses. This revolutionary feature allows for 27 unique SKUs in one product, including selectable options of three Correlated Color Temperatures (CCTs), three lumen outputs, and three optical distributions, ensuring a perfect match for any outdoor lighting scenario.

This innovation significantly simplifies the stocking and ordering process for distributors and contractors. With the OPTI-SELECT AREA LIGHT, the necessity for custom orders well in advance is eliminated, allowing distributors to maintain inventory more efficiently and contractors to simplify project requirements by utilizing one product to meet their various needs, streamlining project timelines.

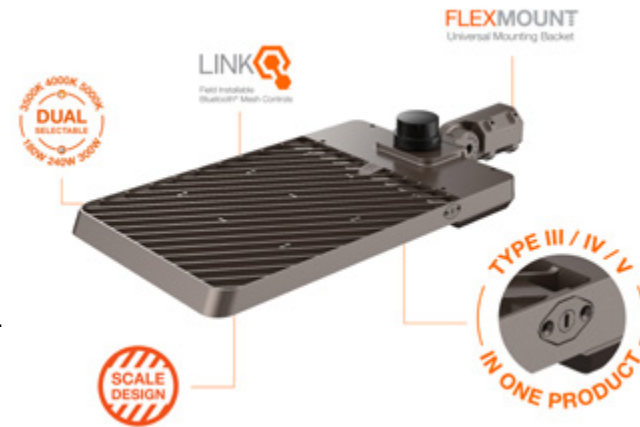

**For more information, visit [www.ledvanceus.com](http://www.ledvanceus.com)**

**Pfannenberg USA Unveils Green Series DTI 6000 Cooling Units**

*Revolutionary closed-loop system ensures clean, cool air for ultimate electronics protection*

Pfannenberg, a leading global manufacturer of thermal management and signaling technologies, announces its new Green Series DTI 6000 Cooling Units. These cooling solutions represent a transformative leap in enclosure cooling technology, protecting vulnerable electronics while protecting the environment.

By employing a closed-loop design, these units effectively seal out ambient air, ensuring the recirculation of clean, cool air throughout the enclosure. This innovative approach provides comprehensive protection for enclosure electronics, safeguarding them against both heat and contaminated ambient air. This system further benefits from the expanded distance between air inlet and outlet, optimizing the air flow within the enclosure to prevent hotspots. Plus, the DTI 6000's integrated design requires less floor space compared to traditional side-mount cooling units, offering space-saving functionality.

The Green Series DTI 6000 Cooling Units offer industry-leading energy efficiency. With Pfannenberg's latest design, customers can achieve up to 11% energy savings, resulting in

a more cost-efficient operation. Additionally, the DTI 6000 reduces the amount of refrigerant used per unit by up to 58% compared to the previous version. This not only reduces the use of these crucial resources but also aligns with current regulations and lowers the system's overall Global Warming Potential.

With versatile power configuration, DTI 6000 owners can seamlessly transition from 400V to 460V with a simple jumper, simplifying retrofitting even for three-phase units. Tool-less mounting and simple installation procedures save valuable time and upfront costs. Plus, easily accessible main system components facilitate straightforward service and maintenance.

UL listed for new UL-60335 requirements, the Green Series DTI 6000 is positioned as a future-ready solution. Pfannenberg's commitment to sustainability and cutting-edge design shines through in the Green Series DTI 6000 Cooling Units. As industries evolve, Pfannenberg continues to lead with innovations that not only meet current needs but anticipate and address the challenges of the future.

**For more information, visit [www.pfannenbergusa.com](http://www.pfannenbergusa.com)**



**Install Peace of Mind!**

**First there was 4 square... and now the REVOLUTIONARY 5 Square® Box!!**

You've struggled with 4 Square boxes for years - you know how small, cramped and time consuming they are. Finally, there is a solution that allows you the space you have always needed.

The 5 Square® Boxes (5" x 5" x 2-7/8") provide up to 88 in<sup>3</sup> of interior volume which more than doubles that of most existing boxes on the market.

Create a robust and unrivaled infrastructure for the life of your facility with the 5 Square® Products!



**Fire Signal**



- TWICE THE VOLUME AS MOST BOXES
- SAVE LABOR...INCREASE PROFITS
- ELIMINATES TROUBLESHOOTING TIME AND COST
- FULLY UPGRADEABLE SYSTEM
- SPECIFIED BY ENGINEERING FIRMS, HOSPITALS, UNIVERSITIES & GOVERNMENT AGENCIES
- AVAILABLE IN ZINC OR RED

**Telecommunications**

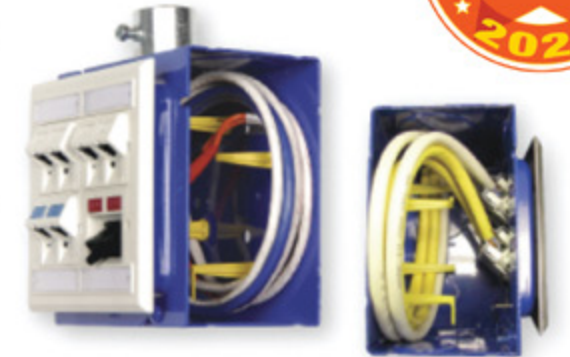

- INTEGRAL CABLE MANAGEMENT
- SAVE LABOR...INCREASE PROFITS
- FACILITATES MIN. BEND RADIUS REQUIREMENTS
- SUPPORTS CURRENT AND EVOLVING SYSTEMS
- SUPPORTS PoE PLUS
- SPECIFIED BY ENGINEERING FIRMS, HOSPITALS, UNIVERSITIES & GOVERNMENT AGENCIES



P: 509.340.0050 • F: 509.340.0051

See our line of telecom & fire signal boxes at: [www.RANDL-INC.com](http://www.RANDL-INC.com)

*Making Communications & Fire Protection More Reliable & Cost-Effective!*

**advertiser**  
INDEX

This advertiser index is compiled as a courtesy to our readers. While every effort is made to provide a complete and accurate listing of companies and page numbers, the publisher is not responsible for errors. **Click the company name or page number to see their advertisement.**

Company	PG#	Company	PG#
APPLETON / EMERSON	15	POWERSIGHT / SUMMIT TECHNOLOGY INC	11
APPLETON / EMERSON	21	POWERSIGHT / SUMMIT TECHNOLOGY INC	16
BARRON LIGHTING GROUP	13	RANDL INDUSTRIES	31
CONDUIT REPAIR SYSTEMS	4	SP PRODUCTS INC	3
ELECTRI-FLEX COMPANY	23	SP PRODUCTS INC	19
iTOOLco	IFC	SP PRODUCTS INC	26, 27
iTOOLco	IBC	SP PRODUCTS INC	BC
KRENZ & COMPANY	32	TIMCO INSTRUMENTS, LLC	25
KUIKBOX	1	UNDERGROUND DEVICES	5
KUIKBOX	17	UNDERGROUND DEVICES	29
MILLER SAFETY CONSULTANTS LTD	7		

# CORDLESS CANNON 6K

**iTOOLco.**

WWW.iTOOLco.com | 865.670.3713



Speed, versatility, and performance are all yours with iTOOLco's Cordless Cannon 6K™. This portable 6,000 lb. puller is intuitively designed to handle all of your day-to-day wire pulls.

The built-in capstan switch automatically turns the puller on and off. Simply tug on the rope to start the pull and slack off the rope to shut it down. Delivers dynamic performance in remote locations or areas where power is not yet available.



When it comes to transformer cooling fans, Krenz-Vent is the industry recognized gold standard. Our leadership position is earned through 80+ years of R&D plus our superior engineering and customer service. You can rest easy when you specify Krenz fans.

**ENGINEERED TO COOL**  
There is no comparison.

**KRENZ & COMPANY, INC.**  
KRENZVENT.COM • 262.255.2310 • KRENZ@KRENZVENT.COM

ALL THE INFORMATION YOU NEED IS JUST A CLICK AWAY AT **WWW.EPSMAG.NET**

**Electrical Products & Solutions**

Transition Couplings  
PVC Bell End Adapter  
Galvanized Rigid Conduit - 1/2" thru 6"

Warming Up to Electrical Heating Cables

WHAT'S NEW

- Conduit Repair Systems, Inc. The World Leader in Split Conduit Products
- DMF Lighting Expands its M Series Commercial Collection with High Lumen Packages for Hospitality and Mix-Use Spaces
- New Multi-Tester from Klein Tools Combines Core Electrical Products into One Model
- RPS Launches SlimWave Filter To Safeguard Motor and Cables



# SPPRODUCTS, INC.

Productivity and value thru ideas  
**FOR SAFER BETTER FASTER JOBS**



We're Proud to be the Electricians' Friend for Over 50 Years!

**IP5**

**"The Original"**

Enter Any KO on Both Sides of the Box



**IP19/20**

4-Conduit Block  
PATENTED

**IP21a**

QwikBlock  
PATENT PENDING

Use 4-Conduit Block (IP19 or IP20) with QwikBlock (IP21a)

**IP6d**

**2-Way**  
with Split Fingers for Horizontal or Vertical Installation

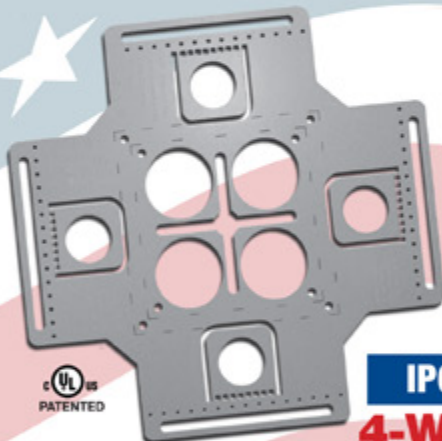
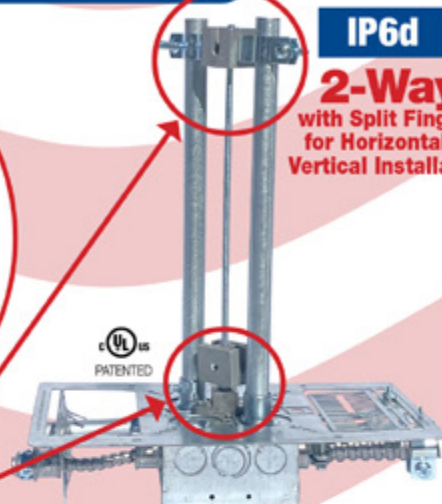

**IP6**

**4-Way**

Enter Any KO on All 4 Sides of the Box Plus 4 Large Open KOs in Center Allows Entering Back of Box

**IP6a**

**2-Way/Half**

Enter Any KO on 1 or 2 Sides of the Box Plus Large Open KOs in Center Allows Entering Back of Box



**MADE IN THE USA!**

Plus More Being Invented for *SAFER BETTER FASTER* Jobs . . . Call With Your Ideas!

SPProducts.com 800-233-8595 info@SPProducts.com

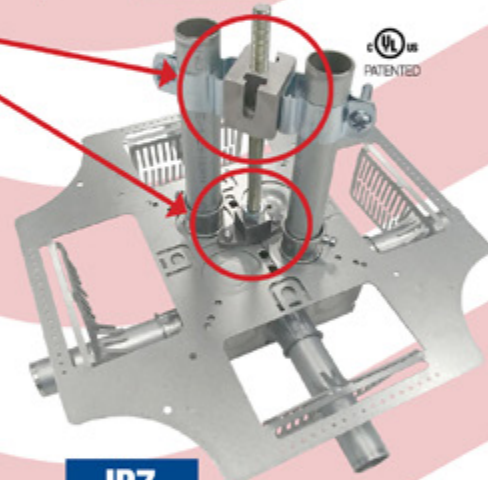

**IP7**

**4-Way**

with Split Fingers for Horizontal or Vertical Installation. Enter Any KO on All 4 Sides of the Box Plus 4 Large Open KOs in Center Allows Entering Back of Box.

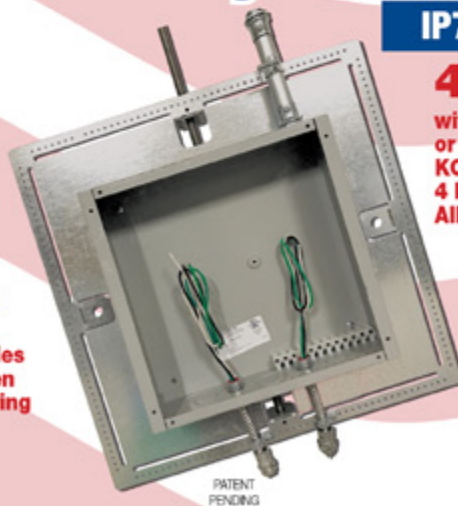

PATENT PENDING

**IP8**

Mount Horizontally or Vertically from One Single Support

**20 x 20**

Supports up to 12 x 12 J-Box

**28 x 28**

Supports up to 20 x 20 J-Box